



CLEARPATH-SC MOTORS

MODELS SCSK AND SCHP

IN NEMA 23 AND NEMA 34 FRAME SIZES

VERSION 1.45 FEBRUARY 6, 2026

THIS PAGE INTENTIONALLY LEFT BLANK

TABLE OF CONTENTS

TABLE OF CONTENTS	3
TOP TIPS FOR CLEARPATH-SC USERS	6
QUICK START GUIDE.....	7
About ClearPath-SC	7
Who Should Use ClearPath-SC Motors?	7
Please Read This Important Warning!.....	7
Description of System Components	8
System Diagram.....	8
SC4-HUB.....	8
DC Bus Power Supply	8
POWER4-HUB	8
Parts of a ClearPath-SC Motor	9
System Setup.....	10
1. Install ClearView Software	10
2. Install the SC Hub "End-Of-Loop" Jumper	11
3. Connect ClearPath-SC System Components	12
4. Test the DC Bus Power Polarity.....	15
5. Establish Communication (USB or RS-232 / Serial) ..	16
Test Spin Your Motors Using ClearView	19
SAFETY WARNINGS	20
Personal Safety Warnings.....	20
CE Compliance Warnings.....	20
General Disclaimer	21
INTRODUCTION	22
What is ClearPath-SC?.....	22
Parts of a ClearPath-SC Motor	24
EXAMPLE CLEARPATH-SC SYSTEMS.....	25
Typical 4-Axis System (Single Port, 1 SC4-HUB)	25
Medium System (Single Port, 3 SC4-HUBs).....	26
Large System (Multiple Ports and SC4-HUBs).....	27
POWERING A CLEARPATH-SC.....	28
Selecting a DC Bus Power Supply.....	28
FAQ: "What size power supply should I use?"	28
Considering a "Lower Voltage" Bus Power Supply?.....	29
Additional Power Supply Considerations	30
Teknic IPC-3 and IPC-5 Power Supplies	31
Teknic Model IPC-3	31
Teknic Model IPC-5	31
Before Powering Your ClearPath-SC System	32
Power Supply Switching and Fusing	33
Direct Power Connection.....	34
Power Chaining Multiple Motors	34
Using the POWER4-HUB	35

POWER4-HUB Overview Diagram	35
POWER4-HUB: Things to Know.....	36
POWER4-HUB: Compliance Notes.....	36
Parts of a POWER4-HUB	37
Connections: One POWER4-HUB	38
Connections: Two POWER4-HUBs.....	39
Auxiliary (24V) Logic Power Supply	40
POWER4-HUB LEDs.....	41
COMMUNICATION AND I/O (THE SC4-HUB)	42
Introduction	42
SC4-HUB Overview	42
Parts of an SC4-HUB	43
SC4-HUB Mounting.....	43
SC4-HUB Operation (Connector by Connector).....	43
24VDC Input / Pass-through Connectors	43
USB Communication Connector (USB Comms)	43
RS-232 Communication Connector	44
ClearPath I/O Connector	44
End-of-loop Headers	44
Input A and B Connectors	45
Brake Control Connectors	47
Global Stop Connector.....	50
Safety Controls Concept Sketch.....	51
CONFIGURATION SOFTWARE (CLEARVIEW).....	52
Minimum System Requirements.....	52
Installing ClearView Software	52
Establishing Communication With Your System.....	53
ClearView Software Tour	53
User Interface Overview	53
Manual Motor Controls	54
Dashboard.....	55
Soft Scope.....	56
ClearView Menus	61
USING THE DIAGNOSTIC CHANNEL.....	77
Terms Used in this Section	77
Connecting to the Diagnostic Channel	78
Changing Diagnostic Channel Access Modes.....	80
Troubleshooting Diagnostic Channel Connections.....	81
SOFTWARE LIBRARY AND SDK OVERVIEW	82
Introduction to the sFoundation Library	82
sFoundation Class Hierarchy	82
INode (Node Level Classes).....	85
IPort (Port Level Classes)	86
SysManager (System Level Class)	87
Software Development Kit (SDK).....	88
APPENDIX A: MOTOR LED BLINK CODES	89
APPENDIX B: MECHANICAL INDEX	90
Mounting Dimensions: ClearPath-SC NEMA 34	90
Mounting Dimensions: ClearPath-SC NEMA 23	91

Motor Mounting, Thermal Considerations	92
Mounting Dimensions: SC Hub.....	93
Mounting Dimensions: Power Hub.....	94
Connecting ClearPath-SC to a Mechanical System	95
Motor Connection: General Tips and Guidelines	95
Notes on Coupling Selection.....	97
Installing Pulleys and pinions	98
About End-of-Travel Stops.....	99
Hard Blocks.....	99
Elastomeric (rubber) Stops	99
Pneumatic (dashpots).....	99
End Stops and Hard Stop Homing.....	99
Fan Mounting and Cooling.....	100
APPENDIX C: MATING CONNECTORS AND CABLE PINOUTS	101
Mating Connectors.....	101
Cable Pinouts	102
Control Cable: CPM-CABLE-CTRL-MU120	102
Control Cable: CPM-CABLE-CTRL-MM660	102
Control Cable: Molex Brand (2 meters and shorter)	103
Power Cable: CPM-CABLE-PWR-MM660	104
Power Cable: CPM-CABLE-PWR-MS120	104
APPENDIX D: SPECIFICATIONS.....	105
ClearPath-SC Motor: Common Specifications.....	105
POWER4-HUB Specifications.....	106
SC4-HUB Specifications	107
APPENDIX E: GROUNDING AND SHIELDING	108
Protective Earth (PE) Connection	108
Grounding and Shielding.....	108
Power Returns	109
APPENDIX F: CIRCUIT SCHEMATICS	110
POWER4-HUB Schematic (simplified).....	110
SC4-HUB Schematic (simplified).....	111
APPENDIX G: WIRING THE INPUTS.....	113
Wiring a Mechanical Switch to an Input.....	113
Wiring a 24V NPN Sensor to an Input	113
Application Example: Wiring an Optical Sensor to an Input	114
APPENDIX H: MOTOR PART NUMBER KEY.....	115
APPENDIX I: LOGIC POWER SUPPLY SIZING.....	116
APPENDIX J: MISCELLANEOUS	117
How to Make a 24V Logic Supply Cable.....	117
Other Product Notes	117
Re: Electrical Fast Transient (EFT) Testing.....	117
ClearPath EMC Instructions.....	118
IPC-3/5 Thermal Derating Data.....	118

TOP TIPS FOR CLEARPATH-SC USERS

These tips apply to the fractional horsepower ClearPath-SC motors covered in this document.

TOP TIPS

- ✓ **Noise at First Enable?** The brief buzzing sound you hear the first time your motor is enabled after power up is the motor initializing itself. This is normal (and necessary).
- ✓ **Motor Killer!** Reversing positive and negative DC bus power to your ClearPath motor will irreparably damage the motor. [More...](#)
- ✓ **USB Cables Matter.** Use only Hi-Speed USB data cables to communicate with your ClearPath motor. “Charger only” cables won’t work.
- ✓ **USB Connector Damage.** Avoid yanking, twisting, or tripping on a USB cable that is connected to a ClearPath USB port. This can break the physical connector (and your ability to communicate with the motor through the rear USB port).
- ✓ **Cover your motor’s USB port** with the included silicone plug when the port is not in use. This will keep out dust, chips, liquids, etc.
- ✓ **Motor Blink Code?** To understand what the various motor blink codes mean, 1) look up blink codes in the user manual (see [Appendix A](#)). 2) Connect to your motor’s USB port to view exception/shutdown messages using the ClearView software.
- ✓ **Auto-Tune Fully Loaded.** Auto-Tune with your motor connected to the mechanics exactly as it will run during normal operation. The default motor tuning file that comes with your motor is designed for no-load operation.
- ✓ **Use different power supplies** for main DC bus power versus low power logic (inputs and outputs). It may be tempting to use the same supply for 24VDC applications, but avoid doing so.

QUICK START GUIDE

This section was created to help users achieve the following objectives:

- Understand the ClearPath-SC system at a high level
- Connect the ClearPath-SC system components
- Install ClearView setup and configuration software
- Establish communication between a ClearPath-SC motor and PC
- Spin a ClearPath-SC motor using ClearView software

ABOUT CLEARPATH-SC

Thank you for choosing the ClearPath-SC all-in-one servo system with full software control. ClearPath-SC gives you the highest level of flexibility and control over your motors and machine application software, because you write it.

In the ClearPath-SC development model, Teknic provides you with the **sFoundation**, an advanced motion software library. ClearPath-SC is compatible with C++ for Windows/Linux and .NET languages (such as C#) for Windows. You write the machine application using development tools like Microsoft Visual Studio.

The included **ClearView configuration and setup software**, allows non-software personnel to tune, test, and exercise the servos right on the machine without coding a single line.

WHO SHOULD USE CLEARPATH-SC MOTORS?

ClearPath-SC users should be proficient in a programming language supported by ClearPath, such as C++ for Windows/Linux and .NET languages (such as C#) for Windows.

If you're not a strong coder, consider ClearPath-MC or ClearPath-SD motors for your project. The **ClearPath-MC family** features an assortment of preprogrammed operating modes, simplified digital controls, and *requires no coding*. The **ClearPath-SD family** accepts standard step and direction or quadrature AB control signals from any compatible controller, indexer, or similar device.

PLEASE READ THIS IMPORTANT WARNING!

Always use caution and common sense when handling motion control equipment. Even the smallest ClearPath motor is powerful enough to crush fingers, tear off a shirt sleeve, or pull out a patch of hair faster than the blink of an eye¹. These devices are extremely powerful and **dangerous if used carelessly**, so please read and follow all safety warnings in the ClearPath-SC User Manual before operating a ClearPath motor.

¹ The average duration for a single blink of the human eye is 100 to 400 milliseconds according to the *Harvard Database of Useful Biological Numbers*.

DESCRIPTION OF SYSTEM COMPONENTS

This section provides a brief overview and description of the main components of a ClearPath-SC system. See the ClearPath-SC User Manual for more information and specifications on system components.

SYSTEM DIAGRAM

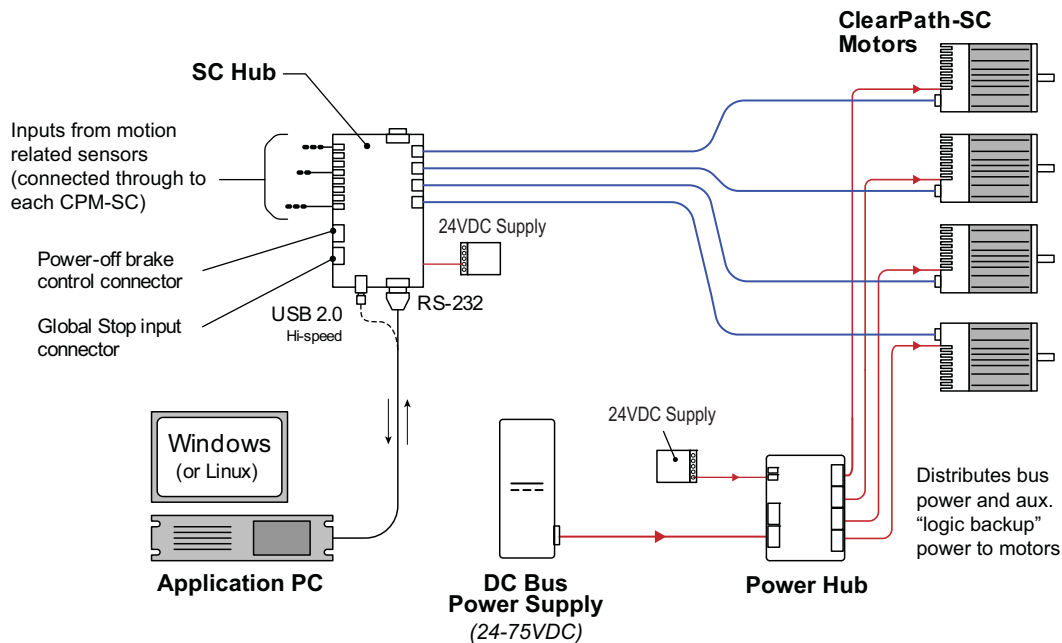

A 4-axis ClearPath-SC System

SC4-HUB

The SC4-HUB connects your computer and I/O devices to your ClearPath-SC motors. The SC Hub routes communication signals, passes sensor/switch inputs to the motors, includes 2 power-off brake outputs, and one Global Stop (e-stop) input. A maximum of 4 SC Hubs can be linked together to create systems of up to 16 axes per port, and up to 3 ports per computer, allowing you to create systems with as many as 48 motion axes.

DC BUS POWER SUPPLY

The DC Bus Power Supply provides main power to your ClearPath-SC motors. A Teknic IPC-5, 75VDC supply is shown above, but ClearPath-SC motors can be powered from other supplies in the 24–75VDC range.

POWER4-HUB

The POWER4-HUB distributes DC bus power and backup logic power to as many as four ClearPath-SC motors per hub. If DC bus power is suddenly lost, the Power Hub will automatically switch to auxiliary logic power to maintain uninterrupted power to the processor, memory, and communication circuits. Multiple Power Hubs can be chained together to support larger systems.

PARTS OF A CLEARPATH-SC MOTOR

Industry-leading, programmable, brushless servo motor with precision optical encoder, built in controller, trajectory generator, servo compensator, and torque drive.

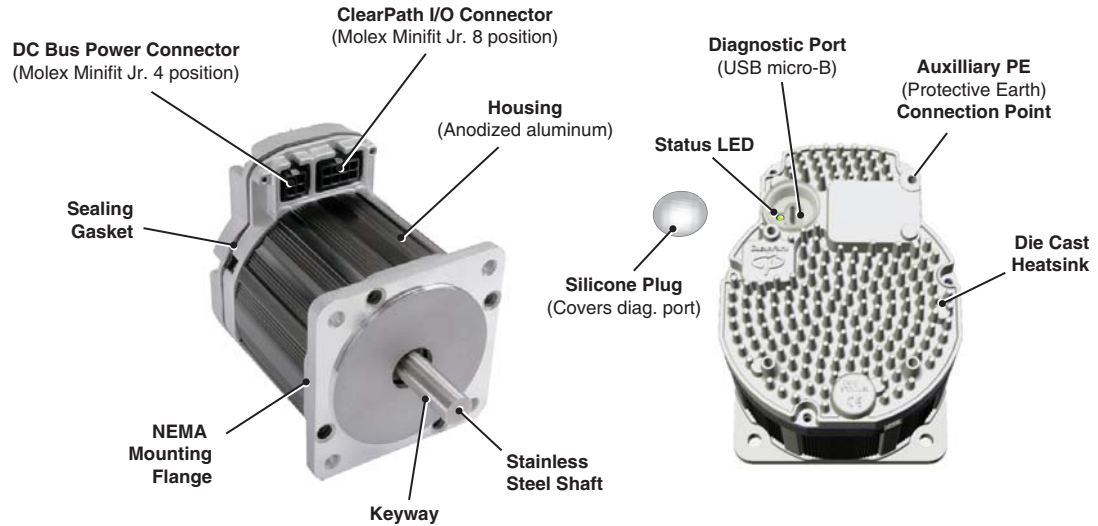

Parts of a ClearPath-SC motor

SYSTEM SETUP

This section describes how to connect ClearPath-SC components, apply power, and establish communication with your PC. We'll show you how to run some basic test moves in the next section.

READ THIS BEFORE POWERING UP A CLEARPATH-SC SYSTEM

- **Do** secure your motors to a stable work surface.
- **Do** keep loose items such as cables, hair, and clothing away from motor shafts.
- **Do** observe static-safe handling practices when handling the SC Hub and Power Hub.
- **Do not** "hot swap" power connectors (i.e. don't connect or disconnect DC power connectors when the DC Bus Supply is powered up). This will cause electrical arcing, carbon scoring, and pitting of the terminals over time.
- **Do** install a protective (finger-safe) guard (or other physical barrier) around the motor shaft.

1. INSTALL CLEARVIEW SOFTWARE

1. Update your Windows installation. See note below for details.
2. Download the ClearView installer from Teknic's website: <https://www.teknic.com/downloads/>
3. Launch the ClearView Installer. Follow the on-screen prompts.

Important Software Installation Note

If your Windows installation is not up to date, ClearView may not run properly on your PC. During installation, the ClearView installer needs access to a few specific Windows system files. If these files are not found, Windows Update will attempt to install them. If Windows Update is disabled, and/or you have no internet connection, this may fail.

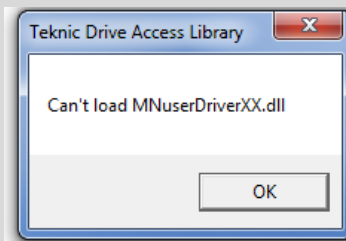

If you install and attempt to run ClearView and see an error window like the one shown above, close ClearView and install this update: <https://support.microsoft.com/en-us/kb/2999226>. Then, re-launch ClearView.

2. INSTALL THE SC HUB "END-OF-LOOP" JUMPER

Place one (and only one) jumper block on the 2-pin header associated with the last motor connected to your SC Hub. Motors must be populated in order from CP0 to CP3 (do not skip motor locations or the system will not communicate properly). Place the jumper on J0 for a single motor, on J1 for two motors, and so forth. See the diagram below for details.

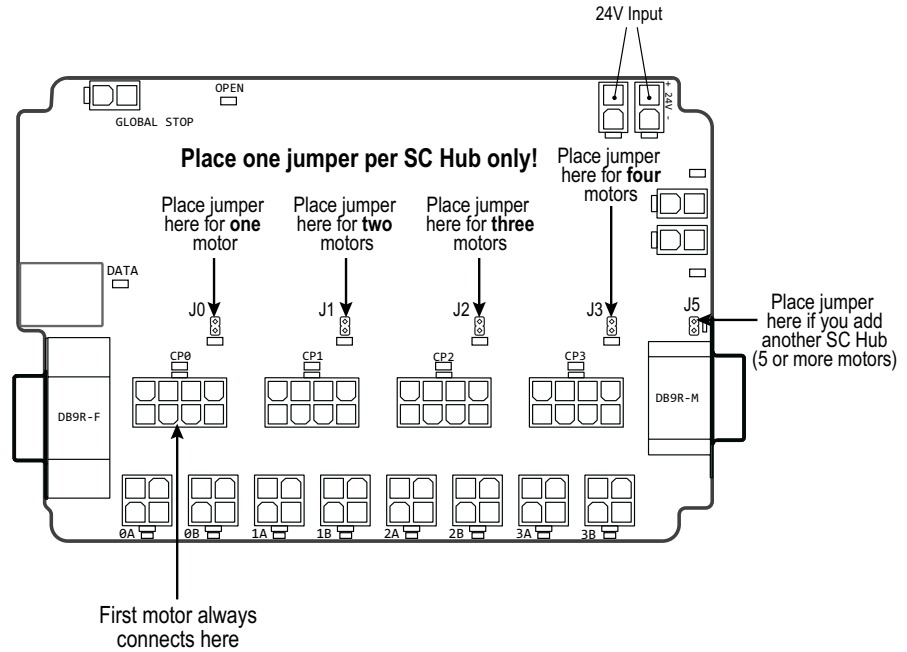

SC4-HUB jumper placement

Note: If you connect a second SC Hub, place one jumper at J5 on the first SC Hub. Then, on the second SC Hub, place one jumper at the last populated motor location.

3. CONNECT CLEARPATH-SC SYSTEM COMPONENTS

Before applying power, connect all ClearPath-SC components as shown in the hookup diagrams later in this section.

Note: Because the Power Hub component is optional, *there are two different versions of the hookup diagram included in this section*. Please refer to the diagram that most closely matches your system.

24 VOLT LOGIC POWER SUPPLY

The SC Hub, Power Hub, and other optional components require a 24VDC nominal power supply to operate. In a small ClearPath SC system (4 axes or fewer) a 50-75 watt logic supply should suffice.

For help estimating how much power (watts) your logic power supply must be rated for, see the appendix "Logic Power Supply Sizing".

Tip: See Appendix J for instructions on how to make an inexpensive, no-crimp power cable for your logic supply.

SYSTEM HOOKUP DIAGRAM (WITH A POWER HUB)

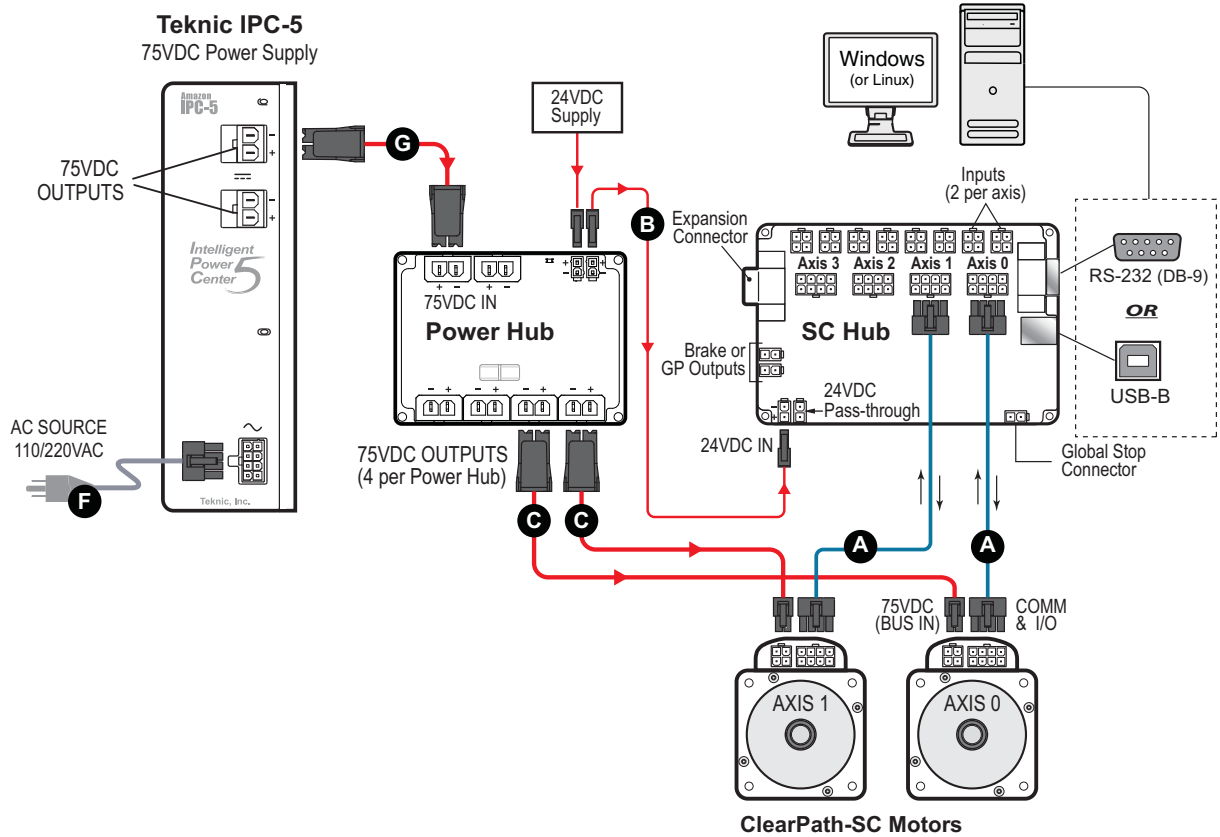

Ref.	Cable Part Number	Description
A	CPM-CABLE-CTRL-MU120	Cable assembly, 120" ClearPath I/O (overmolded Molex Minifit 8-pin to standard Molex Minifit 8-pin).
B	CPM-CABLE-M2P2P-120	2-pin Molex to 2-pin Molex multi-purpose cable, ~10 ft long.
C	CPM-CABLE-PWR-MS120	Cable assembly, 120" ClearPath PWR (Minifit 4 over molded Molex to Sabre).
D	CPM-CABLE-USB-120AB	ClearPath USB Cable; A-male to B-male. 120 inches (3.05m) in length.
E	CPM-CABLE-USB-120	ClearPath USB Cable; A-male to Micro-B. 120 inches (3.05m) in length.
F	IPC35-CABLE110	AC Line Cord (110V) for Amazon IPC-3 and IPC-5 power supplies. Includes NEMA 5-15P to Minifit 8 pin connector, 78.25 inches in length (nominal).
G	PC-SBR-72	Power cable, Sabre to Sabre, 72".

ClearPath-SC Hookup Diagram (for systems with a Power Hub)

SYSTEM HOOKUP DIAGRAM (WITHOUT POWER HUB)

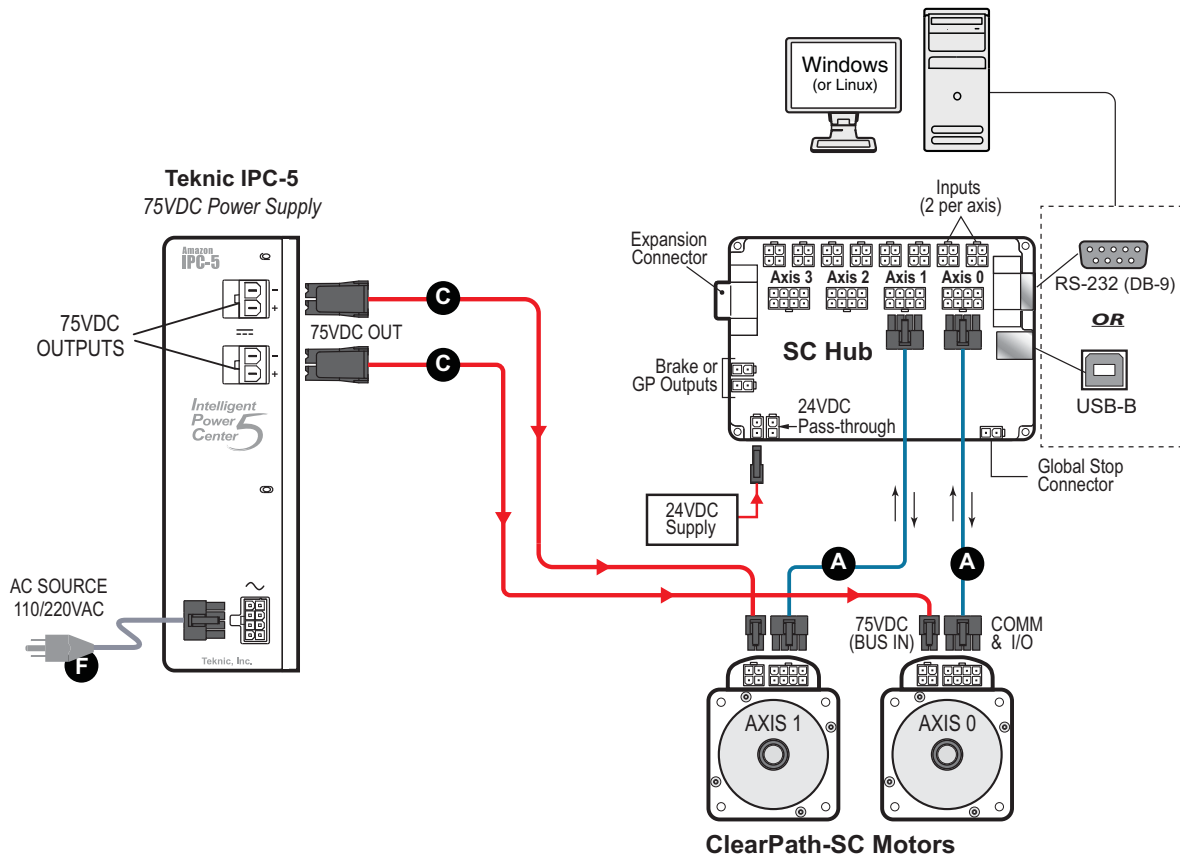

Ref.	Cable Part Number	Description
A	CPM-CABLE-CTRL-MU120	Cable assembly, 120" ClearPath I/O (overmolded Molex Minifit 8-pin to standard Molex Minifit 8-pin).
B	CPM-CABLE-M2P2P-120	2-pin Molex to 2-pin Molex multi-purpose cable, ~10 ft long.
C	CPM-CABLE-PWR-MS120	Cable assembly, 120" ClearPath PWR (Minifit 4 over molded Molex to Sabre).
D	CPM-CABLE-USB-120AB	ClearPath USB Cable; A-male to B-male. 120 inches (3.05m) in length.
E	CPM-CABLE-USB-120	ClearPath USB Cable; A-male to Micro-B. 120 inches (3.05m) in length.
F	IPC35-CABLE110	AC Line Cord (110V) for Amazon IPC-3 and IPC-5 power supplies. Includes NEMA 5-15P to Minifit 8 pin connector, 78.25 inches in length (nominal).
G	PC-SBR-72	Power cable, Sabre to Sabre, 72".

ClearPath-SC Hookup Diagram (for systems without a Power Hub)

4. TEST THE DC BUS POWER POLARITY

Before applying DC bus power to your motor, please perform this quick test. It is well worth the few minutes it takes, and may save you significant amounts of time, money, and frustration.

IMPORTANT: Reversing DC Bus polarity *will* permanently damage your ClearPath-SC motors.

1. Start with the 4-pin power connector disconnected from your ClearPath-SC motor and the AC unplugged.
2. Power up your DC Bus Power Supply.
3. With a DMM, measure the voltage from V+ to GND. See diagram below for pin locations. You should measure a *positive* value of DC voltage. (The actual voltage measured depends on your supply.) **If you measure a negative value, the polarity is reversed.** Fix the problem and measure again.
4. Remove power from your supply.
5. Reconnect the 4-pin power connector to your ClearPath-SC motor and power up.

IMPORTANT: CHECK DC BUS VOLTAGE POLARITY!

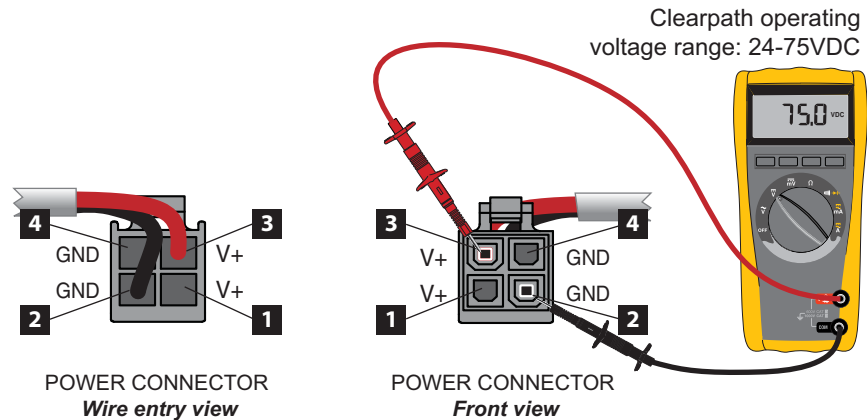

Testing polarity of DC Bus

5. ESTABLISH COMMUNICATION (USB OR RS-232 / SERIAL)

Next, you'll need to establish communication between your PC and the ClearPath-SC motors you want to control. There are two communication protocols available, USB or RS-232. Each is described in this section.

USB COMMUNICATION

1. Power up your ClearPath-SC system.
2. Connect USB cable from the SC Hub to your PC. This is a standard USB-A (male) to USB-B (male) cable.



USB-A (male) to USB-B (male)

3. Wait! Allow the drivers to auto-install. This may take a minute.
4. Launch the ClearView software.
5. ClearView will immediately attempt to auto-detect your motors. If all is well, you will see your motor(s) appear in the Motor List in ClearView.

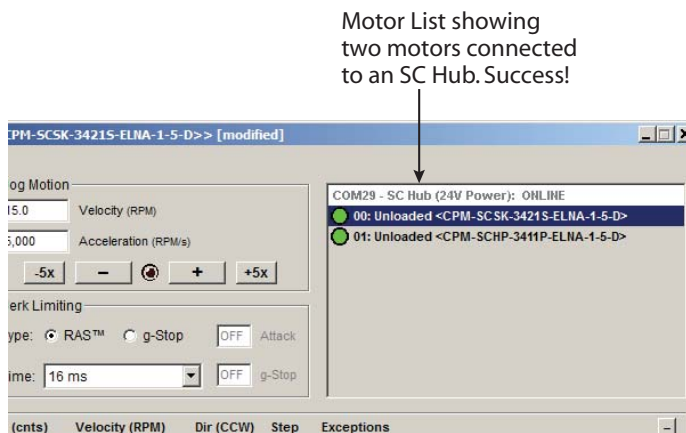

Two ClearPath-SC motors recognized in ClearView

6. If ClearView does not auto-detect your motors. Follow the steps described in *Setting the USB COM Port Manually*, below.

Setting the USB COM Port Manually

1. Open Device Manager (Windows systems).
2. Double-click "Ports (COM & LPT)".

- Under Ports, locate "Teknic ClearPath 4-Axis Comm Hub (COM[n])". Take note of the value [n]—this is your COM port number.

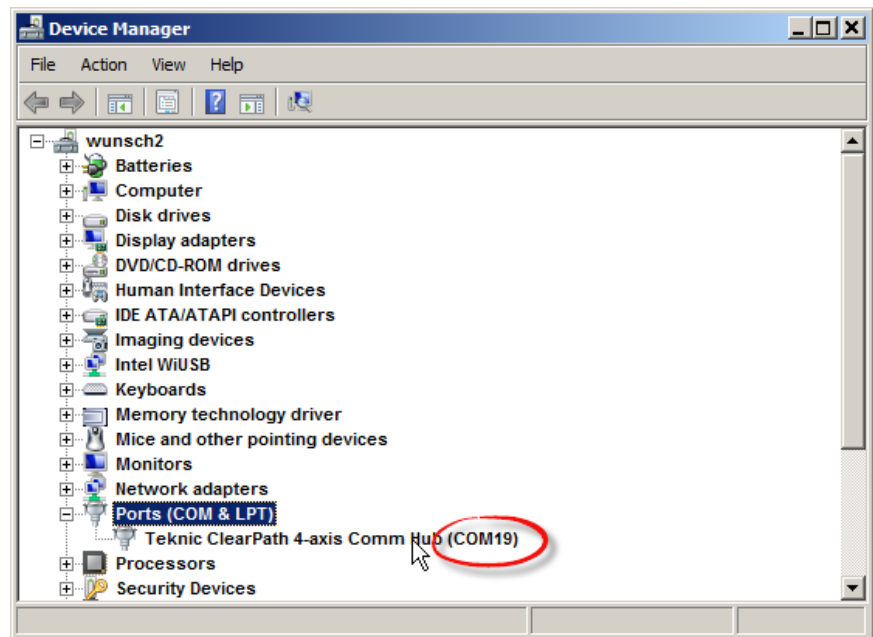

- In ClearView software go to File>Preferences.
- Click the drop down menu in the section labeled "First".
- Select the COM port [n] you identified above. Click "Done".

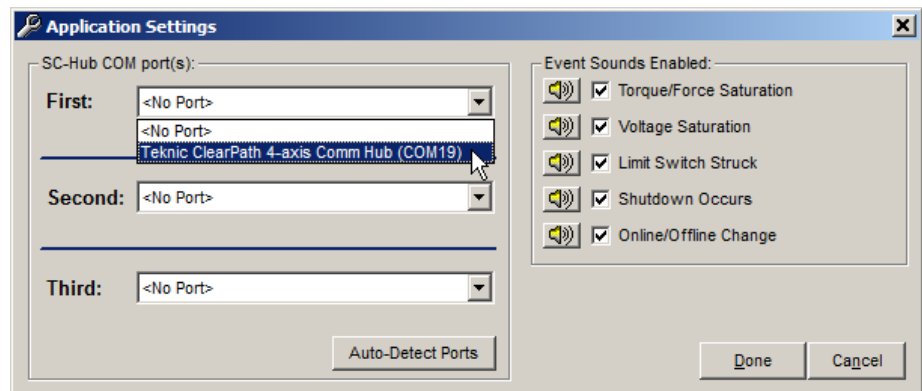

Select "Teknic ClearPath 4-axis Comm Hub" for First COM port

RS-232, SERIAL COMMUNICATION

Important: *If you choose serial communication, your serial port must support a **minimum of 230k baud** to run ClearView software.* If you do not know what speeds are supported by your serial port, check Windows Device Manager under Ports, or refer to your computer's documentation. Note: Applications running *without* ClearView will run properly down to 115k baud minimum.

If you want to use serial communication, and your serial ports aren't fast enough, you can find high speed serial port cards online from companies such as Axxon (softio.com) and Perle.

1. Power up your ClearPath-SC system.
2. Connect your serial communication cable (DB-9 to DB-9, straight-through) from the SC Hub to your PC.
3. Launch the ClearView application.
4. Click File>Preferences. A dialog box will pop up. In the section labeled "First", select the COM port number assigned to the serial port you are using.
5. Click "Done".

TEST SPIN YOUR MOTORS USING CLEARVIEW

*Note: This section describes how to spin an unloaded motor (i.e. a motor with nothing attached to the shaft). Important: ClearPath-SC motors ship out pre-configured for unloaded use only. **You must run the Auto-Tune application whenever you connect your motor to a different mechanical system.***

Click and spin—no code required! Once your system is powered up and communicating, you can take your motors for a test spin using ClearView's Move Generator or Jog Motion controls. Here's how:

1. Select the motor you'd like to spin from the Motor List.
2. Set the Move Type: Back and Forth, Single, or Repeating.
3. Enter the Move Parameters: Distance, Velocity, Acceleration, and Dwell (Dwell is just the rest period between repeating moves).
4. Click Enable/Disable button once to enable the motor.
5. Click "Start Motion" (+ or -) button. Hit "+" to start motion in the counter clockwise direction; hit "-" to start motion in the clockwise direction
6. Single click the "Stop" button to end motion cycling. Double click the Stop button to stop motion immediately.
7. Click "E-Stop All" or hit your Esc key to stop motion immediately.

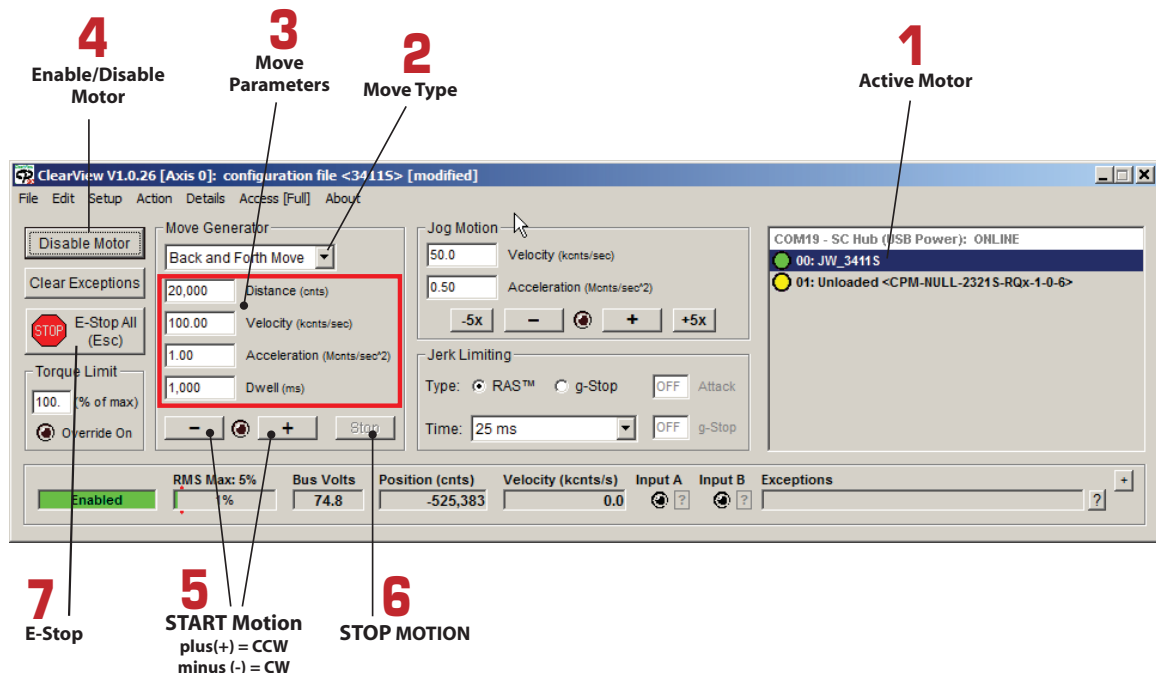

ClearView Main UI

-----End Quick Start Guide-----

SAFETY WARNINGS

IMPORTANT: Read this manual before attempting to install, power up, or operate a ClearPath motor. Failure to understand and follow the safety information presented in this document could result in property damage, bodily injury, or worse.

PERSONAL SAFETY WARNINGS

- Do not wear loose clothing or unconfined long hair when using ClearPath-SC motors. Remove ties, rings, watches and other jewelry before operating an unguarded motor.
- Do not operate a ClearPath-SC motor if your alertness, cognitive function, or motor skills are impaired.
- Always handle, and carry a ClearPath-SC motor by the housing (don't carry it by the shaft or cable). Be aware that in certain scenarios ClearPath-SC is may spin as soon as main DC power is applied.
- Always understand how to use ClearPath-SC software controls and associated features before attempting to power, enable, or otherwise operate a ClearPath-SC motor.
- Install and test all emergency stop devices and controls before using ClearPath-SC.
- Before applying DC power, secure the ClearPath-SC motor to a stable, solid work surface and install a finger-safe guard or barrier between the user and the motor shaft.
- Provide appropriate space around the ClearPath-SC motor for ventilation and cable clearances.
- Do not allow cables or other loose items to drape over, or rest near the ClearPath-SC motor shaft.
- Never place fingers, hands, or other body parts on or near a powered ClearPath-SC motor.
- Thoroughly test all ClearPath-SC applications at low speed to ensure the motor, controls, and safety equipment operate as expected.

CE COMPLIANCE WARNINGS

- There are no user serviceable parts inside.
- Follow all instructions and use the product only as directed.
- Safety of any system incorporating this equipment is the responsibility of the system designers and builders.
- The machine designers need to recognize and incorporate required warning symbols, guards and shields for ClearPath-SC motors that are used in applications that can result in the external accessible parts of their machine exceeding a

temperature of 65 Celsius. This is required as a method to reduce burns. A tool shall be required to remove any guards and/or shields.

- ClearPath-SC motors require that a path exist between the motor chassis and the Protective Earth (PE) connection of the machine to which it is affixed. (Note: The PE connection is often satisfied by simply bolting the motor to the machine; however it is the users responsibility to verify the PE connection.) If an external grounding wire is required, use the same or larger wire gauge as used between the DC power supply and ClearPath Motor.
- Any maintenance or repair guide created by the user shall state that power shall be removed before the Protective Earth ground conductor is disconnected. When reconnecting power, the Protective Earth ground conductor shall be the first wire reconnected. Main power may be reconnected only after the Safety Ground connection is secure.
- When the ClearPath-SC motor is mounted in an application where the shaft end is higher than the electrical connection end of the motor, the USB connector plug provided by Teknic must be installed. The USB plug in these installations becomes an element to prevent the spread of fire per EN 61010-1 section 9.3.2 part c.

GENERAL DISCLAIMER

The User is responsible for determining the suitability of products for their different applications. The User must ensure that Teknic's products are installed and utilized in accordance with all local, state, federal and private governing bodies and meet all applicable health and safety standards.

Teknic has made all reasonable efforts to accurately present the information in the published documentation and shall not be responsible for any incorrect information which may result from oversights. Due to continuous product improvements, the product specifications as stated in the documentation are subject to change at any time and without notice. The User is responsible for consulting a representative of Teknic for detailed information and to determine any changes of information in the published documentation.

If Teknic's products are used in an application that is safety critical, the User must provide appropriate safety testing of the products, adequate safety devices, guarding, warning notices and machine-specific training to protect the operator from injury.

INTRODUCTION

WHAT IS CLEARPATH-SC?

ClearPath-SC is a multi-axis, servo-controlled motion system that allows you to connect up to 16 (or more) integrated servo motors into a tightly coordinated network. Inside each individual ClearPath-SC—in a package about the size of a normal motor—is a rare-earth brushless motor, a powerful servo drive, a motion trajectory generator, and a high-resolution optical encoder. ClearPath-SC's high performance, all-in-one convenience, and low cost makes it practical to use multi-axis servo control in any automated machinery application.

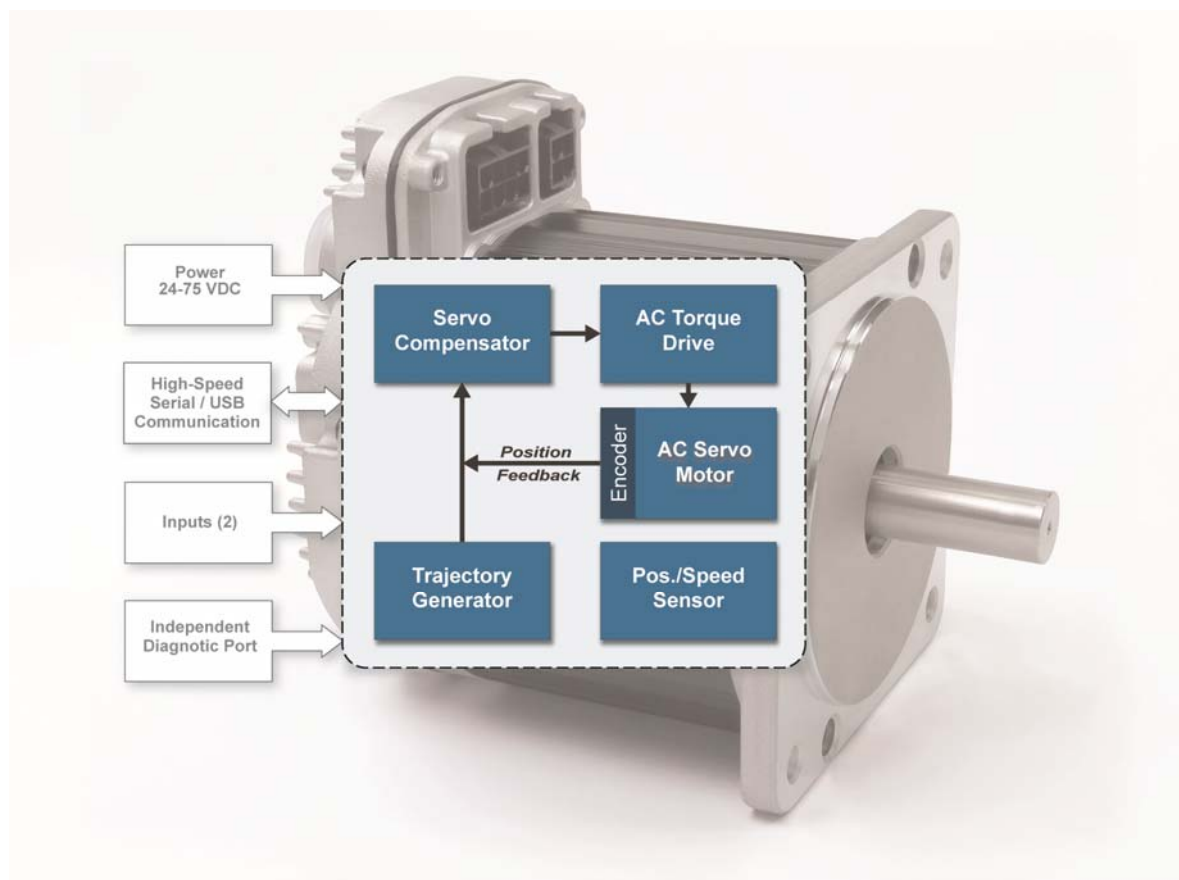

ClearPath-SC all-in-one servo motor

ClearPath-SC is a rugged, industrial-grade product. The motor subsystem is based on Teknic's [Hudson family](#) of brushless servo motors, with similar instrument grade bearings, stainless steel shaft, windings, rare earth magnets, and encoder technology. The servo drive electronics and motion control firmware employ the same state-of-the-art technology and advanced motion control algorithms as our high-end, non-integrated servo control products.

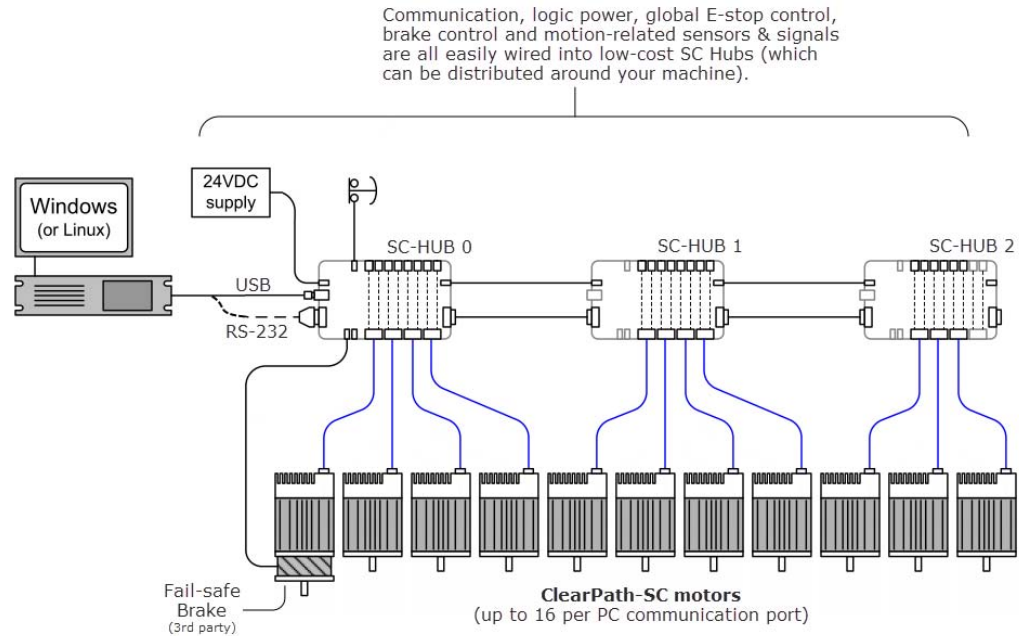

Example ClearPath-SC network. (DC bus wiring not shown.)

Tightly coordinate up to 16 or more motion axes per port (or more). ClearPath-SC's free C++ and .NET class libraries make it possible to write software for complex multi-axis applications. Simple applications can be written in a single execution thread, and, for more sophisticated systems, ClearPath-SC supports multi-threaded applications as well. Optional advanced firmware allows you to generate user-defined interrupts (attentions) for a variety of system events, allowing you to create highly responsive and deterministic multi-axis systems.

ClearPath-SC features a quick, automatic setup. Install the included ClearView software, connect ClearPath to your PC via USB or high-speed RS-232, and let it auto-tune itself to your mechanical system for optimum servo performance.

ClearView software allows you to get moving quickly. You can set many motor parameters, and exercise your mechanical system and electronics with just a few mouse clicks.

Safety and self-protection features are standard. ClearPath-SC will rapidly shut down if it becomes overloaded, overheated, detects a hard stop, or exceeds any of the safety or motion limits you specify.

Made in USA. Each ClearPath-SC motor is built and tested in our New York manufacturing facility, so you can be certain you're getting a high quality, fully tested motion control product right out of the box. And, Teknic backs up each ClearPath-SC motor with a three year warranty.

PARTS OF A CLEARPATH-SC MOTOR

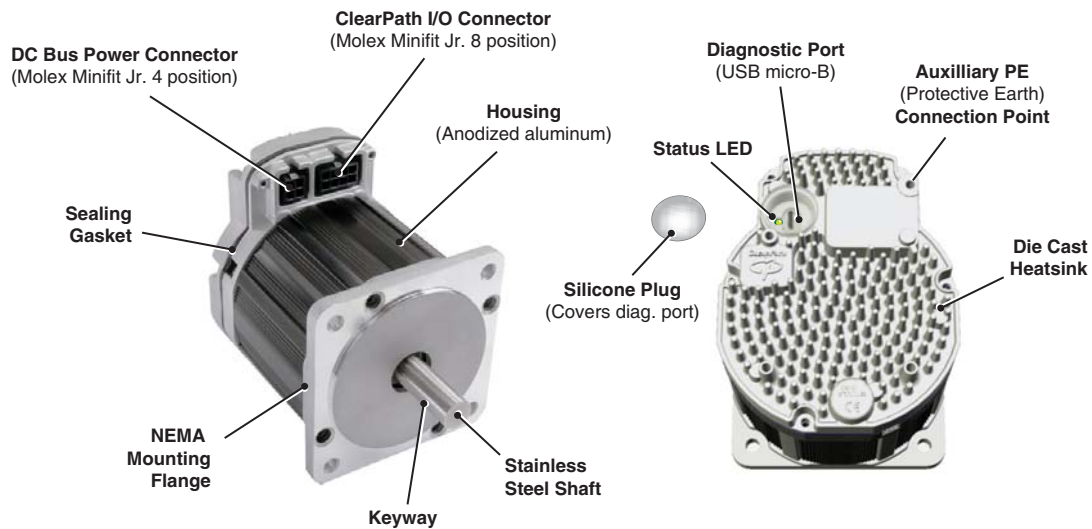

ClearPath-SC Motor

DC BUS POWER CONNECTOR

Function: Input for main DC motor power (24-75VDC).

Connector type: 4-pin Molex Minifit Jr.

CLEARPATH I/O CONNECTOR

Function: Carries communication and input signals to ClearPath-SC.

Connector type: 8-pin Molex Minifit Jr.

DIAGNOSTIC PORT

Function: Provides USB connectivity between ClearPath-SC and an optional diagnostic laptop or PC. Connect to this port with a standard USB cable (Type A to Micro-B). A silicon plug is provided to protect the port from dust, dirt, etc. when not in use.

Connector type: USB Micro-B (female)

STATUS LED

Function: Indicates operational status of ClearPath-SC. LED codes are explained in the *LED Blink Codes* appendix.

AUXILIARY PROTECTIVE EARTH CONNECTION POINT

This is an unthreaded screw boss that can serve as a connection point to Protective Earth ground if the motor is not otherwise bonded to PE through the machine frame or other means.

EXAMPLE CLEARPATH-SC SYSTEMS

The ClearPath-SC system was created with both design flexibility and expandability in mind. This section shows a few examples of systems that can be built with ClearPath-SC components.

TYPICAL 4-AXIS SYSTEM (SINGLE PORT, 1 SC4-HUB)

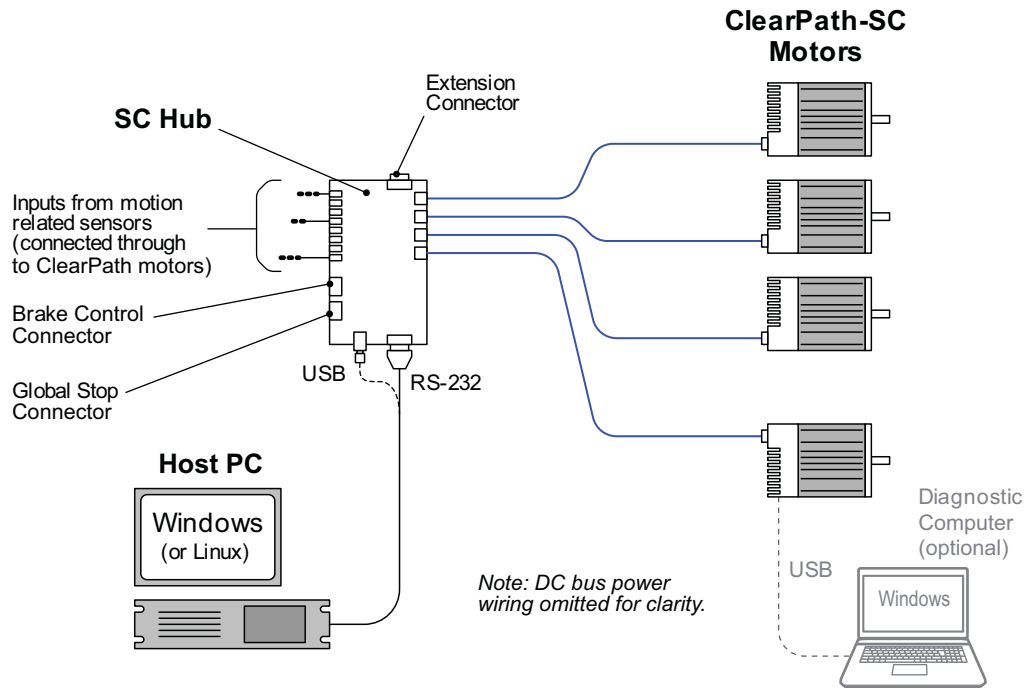

4-axis ClearPath-SC system

MEDIUM SYSTEM (SINGLE PORT, 3 SC4-HUBS)

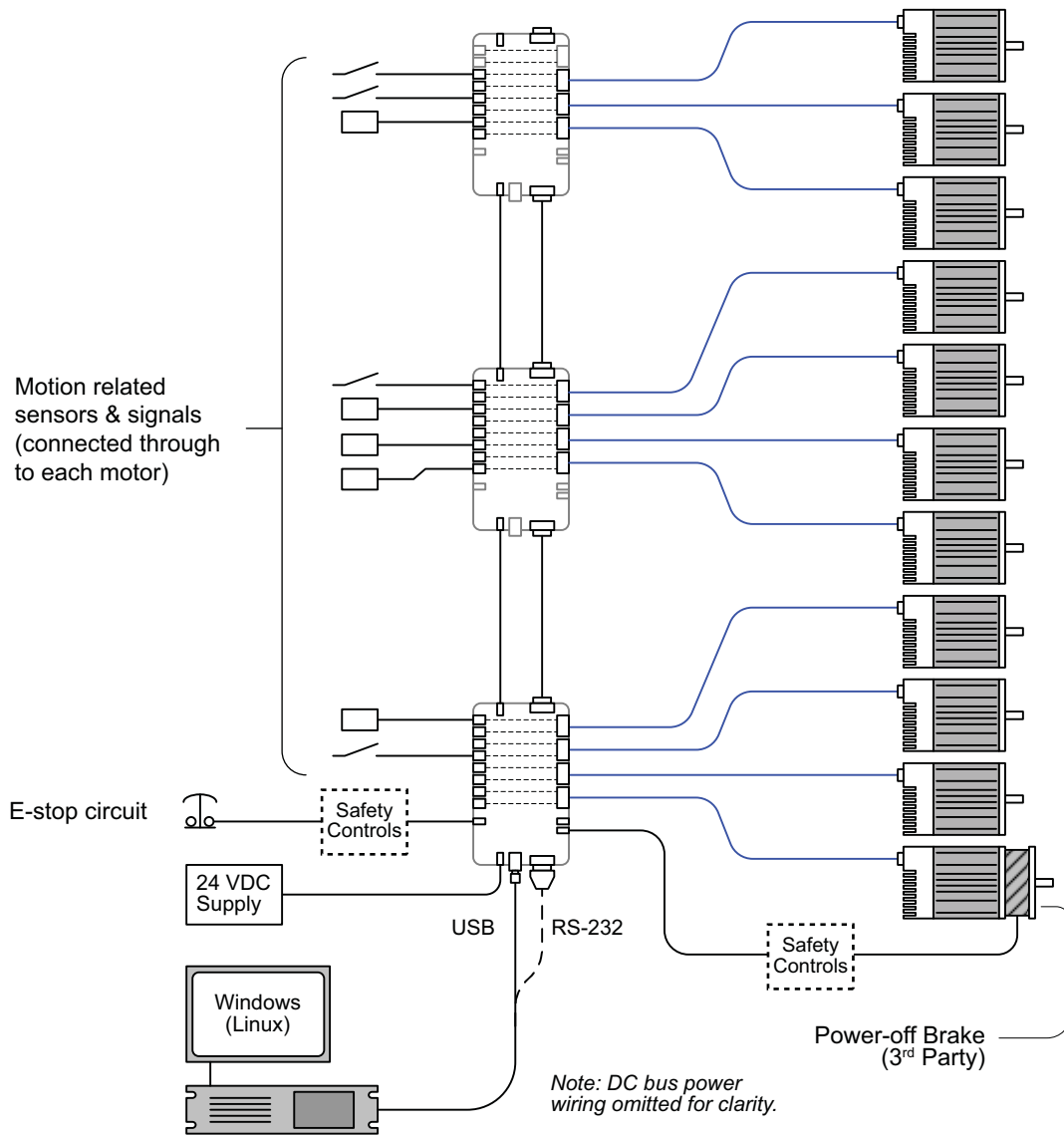

Medium system with multiple SC-Hubs connected to one computer port
 Active sensors powered through SC-Hub, e.g., proximity, optical, Hall-effect type, etc.
 24V Power-off brake shown wired for axis 0

LARGE SYSTEM (MULTIPLE PORTS AND SC4-HUBS)

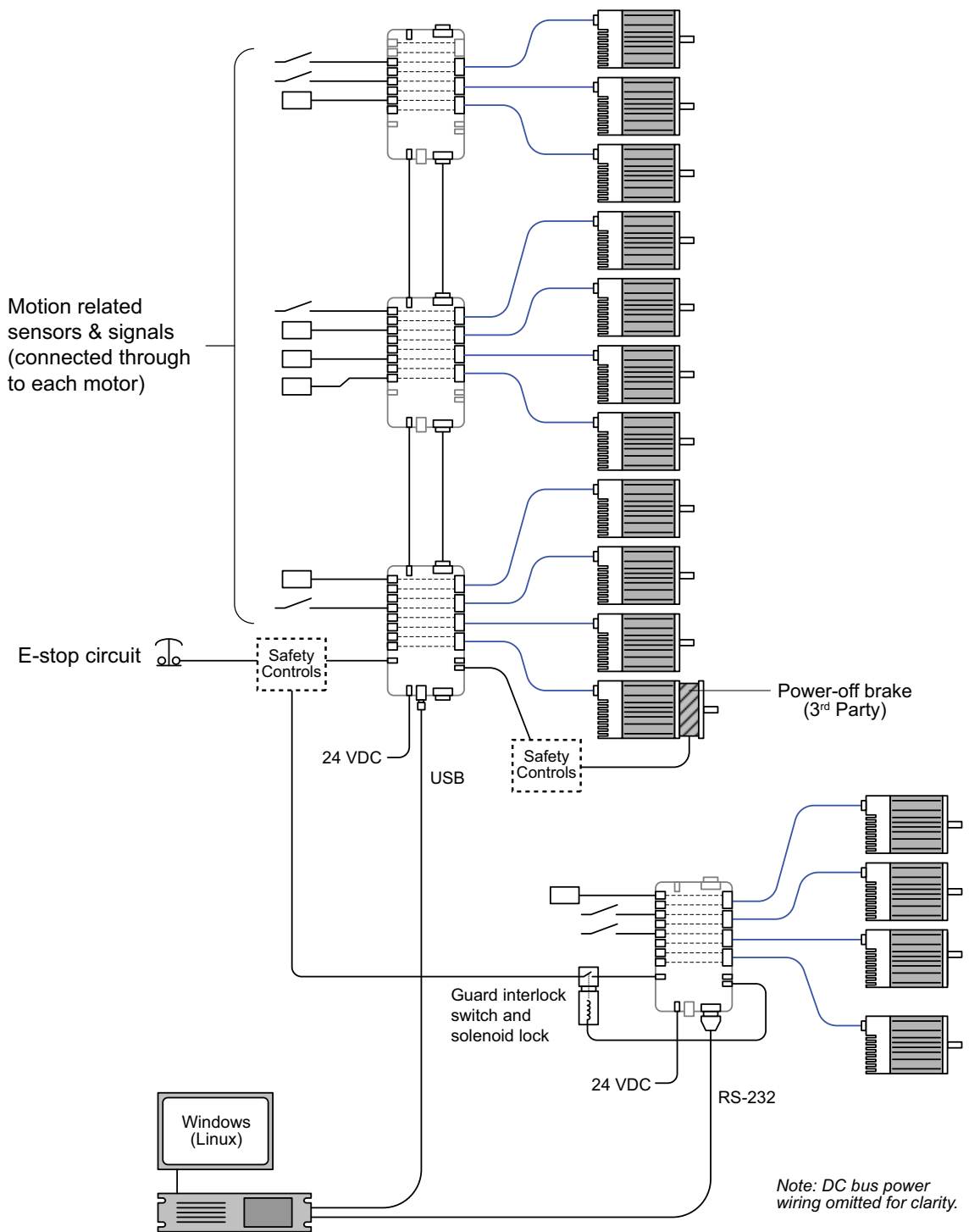

Large system with multiple SC-Hubs connected to two ports
 Two area machine with guard lock under software control in one area
 24V Power-off brake shown wired for one axis
 Mix of mechanical switches and active sensors powered from SC-Hub

POWERING A CLEARPATH-SC

This section covers DC bus power requirements for ClearPath-SC motor systems. Note: "DC Bus Power Supply" refers to the DC source that delivers the power to the motor windings that drives motion.

SELECTING A DC BUS POWER SUPPLY

THE IDEAL CLEARPATH-SC POWER SUPPLY...

...should be able to deliver high peak current, and be able to manage back-EMF (reverse voltage generated by the spinning motor that opposes the incoming supply voltage).

A power supply specifically designed for motor drive power—like Teknic's IPC-3 and IPC-5—will have these features, and are ideal for servo systems like ClearPath-SC. "Bulk" linear power supplies (basically a transformer, rectifier, and large capacitor) can also work adequately. Typical switching-mode power supplies are not recommended.

Important: Thoroughly test your ClearPath-SC application with the intended power supply, *under worst case, full load conditions*, to ensure sufficient power capacity and adequate operating margin.

FAQ: "WHAT SIZE POWER SUPPLY SHOULD I USE?"

Our engineers are asked this question all the time, and the short answer is: "it depends".

The exact power requirements for a given machine depend on several interrelated factors, including the number and type of motors and drives connected to the supply, the torque and speed requirement for each motor, environmental factors, and more.

Calculating the torque requirement for just a single axis can be challenging. This involves analysis of gearing, loading (both static and dynamic), reflected inertia, gravitational effects, friction, target accelerations, velocities, and machine throughput requirements.

Then comes the tricky part: analyzing the machine as a system, i.e. as a group of axes working together under all possible operational conditions. At the systems level, factors such as axis duty cycle, effects of synchronous motion, and regenerated energy come into play.

So, selecting a power supply often begins with an educated guess followed by real-world testing. If you need to power several motors running at high speed and high torque, consider trying a Teknic IPC-5, 75VDC power supply. Start with one supply but keep in mind that you can add another supply later if your application requires more power. If your machine is a single axis moving a light load at relatively low speed, a less powerful supply will likely suffice. Just be aware that testing may be required to find the right solution.

CONSIDERING A "LOWER VOLTAGE" BUS POWER SUPPLY?

ClearPath-SC motors do work with DC bus power supplies down to 24VDC, but *the supply must have sufficient voltage, current, and capacitance to meet your system's torque and speed requirements.*

Less power in means less power out. A lower voltage bus supply will limit ClearPath-SC top end speed and torque, and may lead to problems including the following:

- **ClearPath-SC is unable to complete the auto-tuning process.** The ClearPath-SC auto-tuning feature uses aggressive moves to test the limits of a mechanical system. A weak power supply (i.e. one that can't handle the peak current demands required by ClearPath-SC) may "droop" below ClearPath's minimum operating voltage (about 21.5VDC). This can cause loss of communication and a protective shutdown. Needless to say, if auto-tune cannot run to completion, you may have an underpowered supply.
- **ClearPath-SC completes the auto-tuning process but experiences certain warnings or shutdowns during programmed motion.** If auto-tune runs to completion, but you experience torque saturation, voltage saturation, and/or tracking shutdowns during regular machine operation, you may be exceeding the supply's voltage and/or current capability.

If you suspect your power supply is underpowered, you can try the following solutions:

- **Lower the commanded acceleration and/or velocity.** Sometimes lowering commanded acceleration and/or velocity can reduce the burden on a weaker power supply enough to eliminate shutdowns caused by "power starvation".
- **Upgrade to a more powerful supply.** Look for a supply with higher voltage, higher peak and continuous current ratings, and higher capacitance.
- **Modify your existing power supply.** In some cases adding a large capacitor and a few inexpensive components to an underpowered supply can boost the supply's performance sufficiently. Note: Consult your power supply manufacturer and an electrical engineer before making any modifications to a commercial power supply.

ADDITIONAL POWER SUPPLY CONSIDERATIONS

OPERATE IN THE 24-75VDC RANGE

Always operate ClearPath-SC within the recommended operating voltage range of 24VDC to 75VDC. Do not operate at the motor's absolute minimum and maximum voltage values, as this will tend to cause shutdowns.

Note: When measuring DC bus voltage, always take measurements *directly at the motor's power connector*—not at the power supply's output connector.

WHY AVOID (MOST) SWITCHING POWER SUPPLIES

Switching power supplies are typically not well suited to high power servo applications because they generally have the same peak *and* continuous-current ratings. This can lead the user to purchase a large—but ultimately under-worked—power supply just to meet peak current requirements.

In addition, most switchers are not designed to handle the regenerated energy that a decelerating motor returns to the power supply. Without special provisions, regenerated energy can cause a switching supply to reset, power cycle, shut down, or even fail.

Engineer's Note: It is very common for machine requirements to change during the development cycle (e.g. "We need higher accelerations, and higher speeds, NOW!"). For that reason, Teknic often recommends beginning a machine project with a robust 75VDC supply. That way, if the project manager decides to increase the moving mass, turn up the speed, decrease cycle times, change gearing, or add another axis to the system, you're more likely to have the necessary power available to handle the new requirements.

TEKNIC IPC-3 AND IPC-5 POWER SUPPLIES

Teknic designed the IPC-3 and IPC-5 power supplies specifically for servo systems like the ClearPath-SC. These supplies deliver a tightly regulated 75VDC and feature large capacitor banks to prevent debilitating droop during peak current demand. The IPC supplies also feature advanced regenerated energy management and many built-in safety and protective features.



Teknic IPC-3



Teknic IPC-5

Teknic 75VDC IPC family power supplies

TEKNIC MODEL IPC-3

The IPC-3 power supply can typically power one to four ClearPath-SC motors. The actual number depends on the application—fewer when the motors are generating high torque continuously at high speeds, and more when the motors are intermittently using bursts of power like in many point-to-point positioning systems. Please visit Teknic’s website (www.Teknic.com) for more information, features, and specifications.

TEKNIC MODEL IPC-5

The IPC-5—fully enclosed power supply—can typically power two to six ClearPath-SC motors. The actual number depends on the application—fewer when the motors are generating high torque continuously at high speeds, and more when the motors are intermittently using bursts of power like in many point-to-point positioning systems. Please visit Teknic’s website (www.Teknic.com) for more information, features, and specifications.

BEFORE POWERING YOUR CLEARPATH-SC SYSTEM

- Check for proper DC bus power polarity. **Reversing DC power polarity *will permanently damage the unit.***
- Make sure the power supply is turned off before connecting to a ClearPath-SC. Connecting and disconnecting the motor from a "hot" power supply will cause electrical arcing that will damage the connectors over time.
- Never connect a ClearPath-SC motor directly to an AC outlet. This will damage the ClearPath-SC motor and void the warranty.
- It is acceptable to daisy chain power to several ClearPath-SC motors provided that the combined current draw of the motors does not exceed 10A during operation. If total combined current draw is expected to exceed 10A, it is appropriate to use star wiring.
- When a ClearPath-SC motor is powered up, the vector initialization algorithm will cause the shaft to rotate slightly (1-4 degrees typical).

POWER SUPPLY SWITCHING AND FUSING

POWER SUPPLY ON/OFF SWITCH

If you need to install a power switch, install an appropriately rated device on the AC input side of the supply (see figure below). Do not install a switch on the DC output side. Switching the DC output side—especially with inexpensive relays—will cause performance degradation over time due to pitting, corrosion and potential contact welding.

DC OUTPUT FUSE

If you require an external fuse on your power supply's DC output (to meet compliance standards for example) it should be installed in line with the positive leg of the DC output wiring as shown below. Use a maximum 10A, time delay (slo blo) fuse. Note: Teknic IPC power supplies are not internally fused on the DC output side.

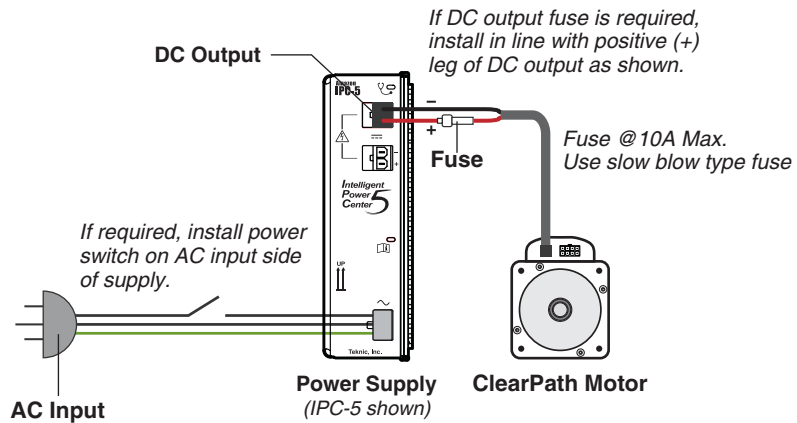

Power supply switching and fusing detail

SAFETY DISCONNECT CONTACTOR

A power disconnect contactor may be placed on the AC input side to satisfy safety system requirements.

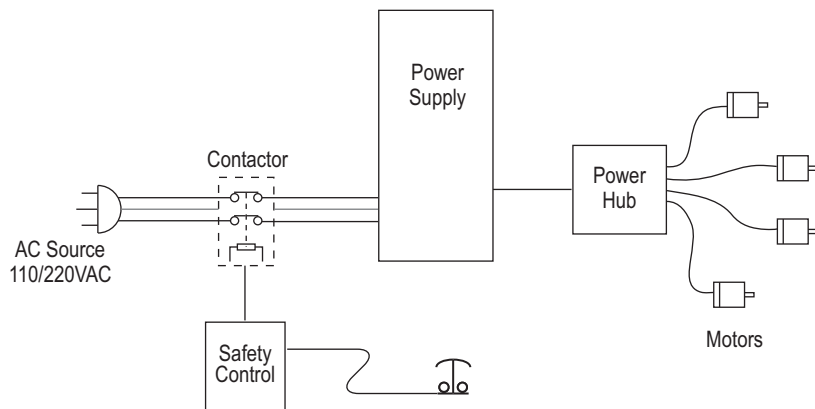

Safety disconnect contactor

DIRECT POWER CONNECTION

One or two motors can be connected directly to the IPC-3 or IPC-5 power supply as shown below. To connect more than two motors, consider using a Power Hub (next page) or chaining power as shown below.

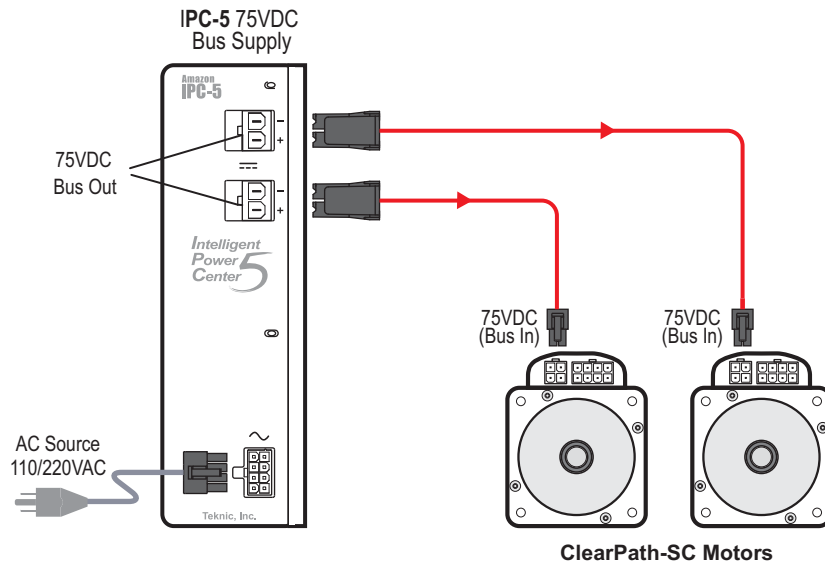

ClearPath-SC direct DC bus power connection

POWER CHAINING MULTIPLE MOTORS

For applications with several ClearPath motors, daisy chaining power from motor to motor (see figure below) may be preferable.

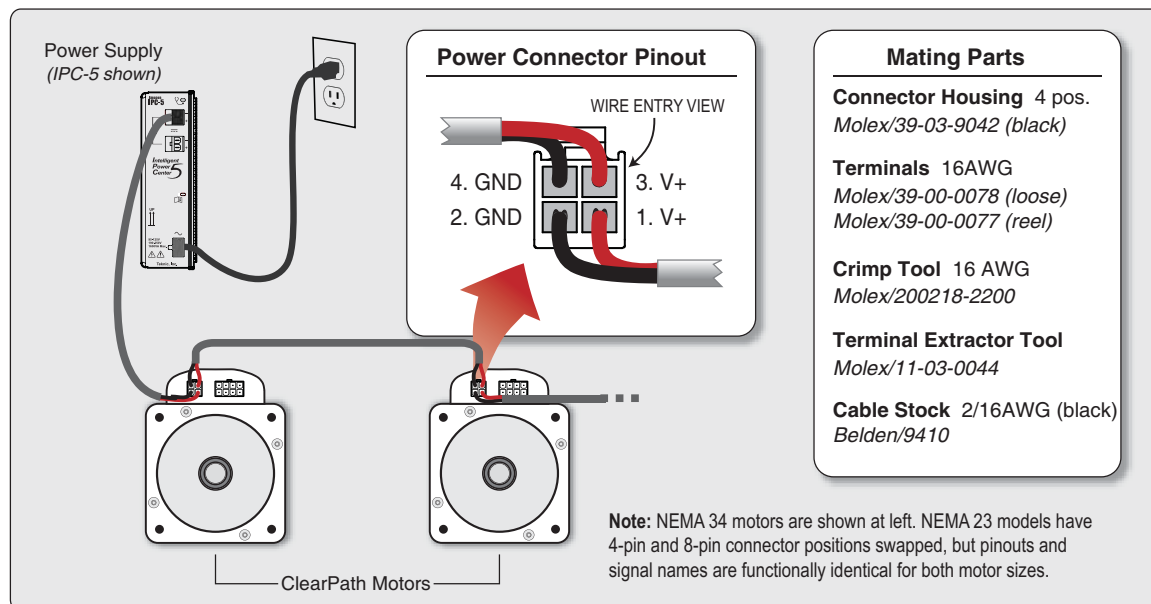

Power chaining ClearPath-SC motors. See [Appendix C](#) for full connector information.

USING THE POWER4-HUB

The Power Hub (Teknic PN **POWER4-HUB**) is an optional ClearPath accessory board that:

1. Distributes DC bus power to as many as four ClearPath motors per Power Hub, thus eliminating the need for special "power chaining" cables.
2. Delivers low voltage **logic power backup** to your ClearPath motors. Logic power backup keeps the motors' electronics "alive" even if DC bus power is dropped. This translates to uninterrupted communication, continuous status monitoring, and retention of encoder position.

Note: You will be unable to spin your motors when using only logic power backup. Logic power backup will keep the motor electronics alive, but is not designed to run motors.

POWER4-HUB OVERVIEW DIAGRAM

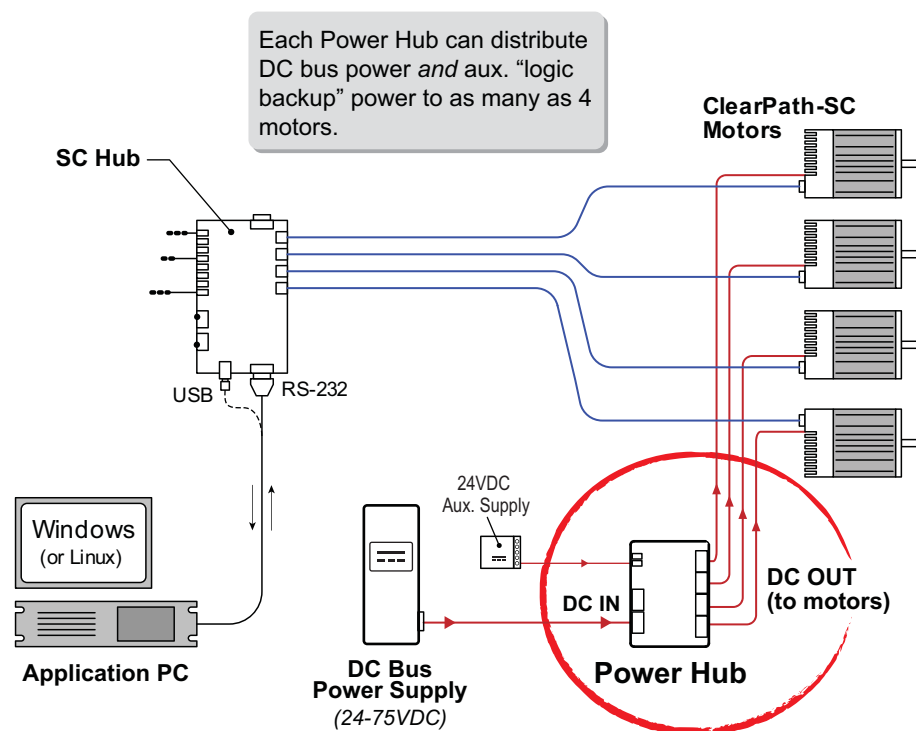

POWER4-HUB in a ClearPath-SC system

POWER4-HUB: THINGS TO KNOW

- **Logic backup power is not designed to spin motors.** It is designed to maintain uninterrupted, low voltage power to the motor electronics (encoder, DSP, communication, I/O, and associated circuits).
- **Damage Warning: Reversing DC bus power polarity to the Power Hub will permanently damage it.** Use a meter to verify correct DC bus power polarity before connecting the power supply to the Power Hub.
- **Do not "hot swap" DC power connectors.** Turn off DC bus power supply before connecting a motor to the Power Hub. *Connecting and disconnecting the motor from a live power supply will cause electrical arcing that will damage the connectors over time.*
- **Logic backup power should not be used as a means of switching DC bus power on and off.** To control DC bus power, use a contactor on the AC side of the DC bus power supply.
- **Do not connect more than two Power Hubs to a power supply.** Continuous and peak current usage must not exceed the power supply's specifications.

It is the user's responsibility to ensure that the DC bus power supply has sufficient continuous and peak power to meet their application requirements.

- **Do not attempt to power more than four ClearPath motors from a single Power Hub.**

POWER4-HUB: COMPLIANCE NOTES

- Any 3rd party (non-Teknic) power supply used with the Power Hub, should be current limited or fused to 25A or less using 25A, 300VDC (UL Listed) fuses.
- If UL compliance is a consideration, select a DC, UL Listed fuse.
- For those seeking a Class G fuse, the **SC-25 from Eaton Cooper Bussmann**, or **OSLCO25 from Littelfuse** is recommended. Fuse holders (also rated this way) include the **HPS-FF and TCFH30N (from ECB/Littelfuse respectively)**.

PARTS OF A POWER4-HUB

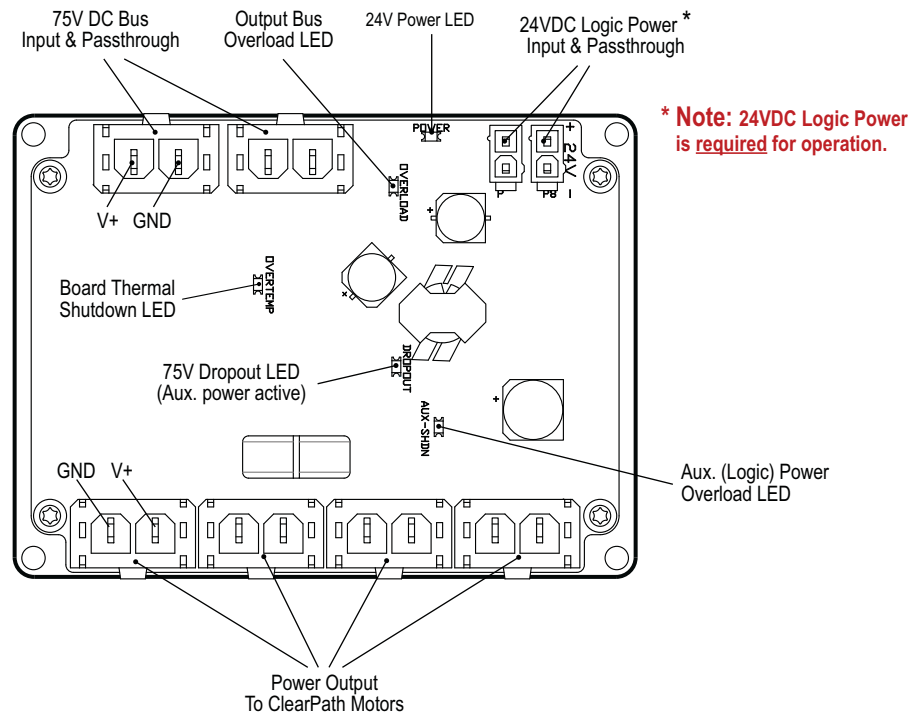

Parts of a POWER4-HUB

DC Bus Power Input/Passthrough (Qty. 2) - Supply 24-75VDC power from your DC Bus Supply to either of these connectors (they are wired in parallel). The other connector can be used to daisy chain bus power to a second Power Hub if desired, or left unconnected.

IMPORTANT: Never connect two IPC-3/-5 power supplies to a single POWER4-HUB. These power supplies are not designed to operate in parallel or series configurations.

DC Bus Power Outputs (Qty. 4) - These four connectors supply bus power to your CP-SC motors. In addition, if power is dropped, they carry aux. power to keep maintain motor communication to the host application. They are fully short-circuit protected.

24VDC Logic Power Input, with Passthrough (Qty. 2) - Supply low power 24VDC logic power to either of these connectors (they are wired in parallel). The other connector can be used to daisy chain power to a second Power Hub.

POWER4-HUB LEDs - There are 5 LED indicators on a Power Hub. Please refer to the section "Power Hub LEDs" (later this section) for a complete explanation of what the Power Hub LEDs indicate.

CONNECTIONS: ONE POWER4-HUB

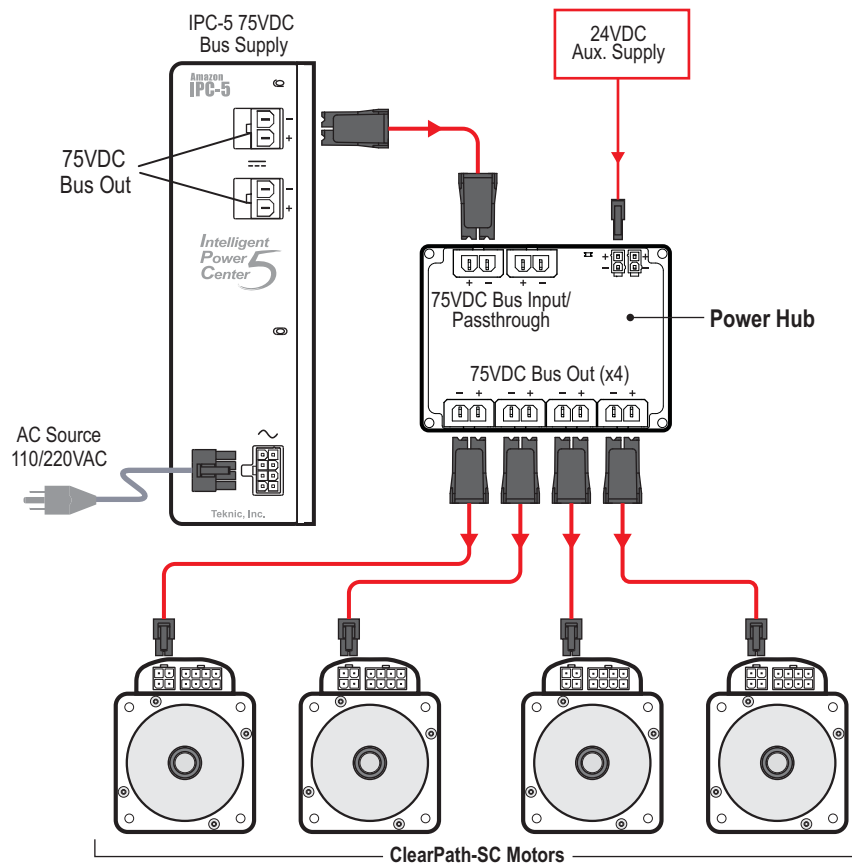

Single POWER4-HUB System

CONNECTIONS: TWO POWER4-HUBS

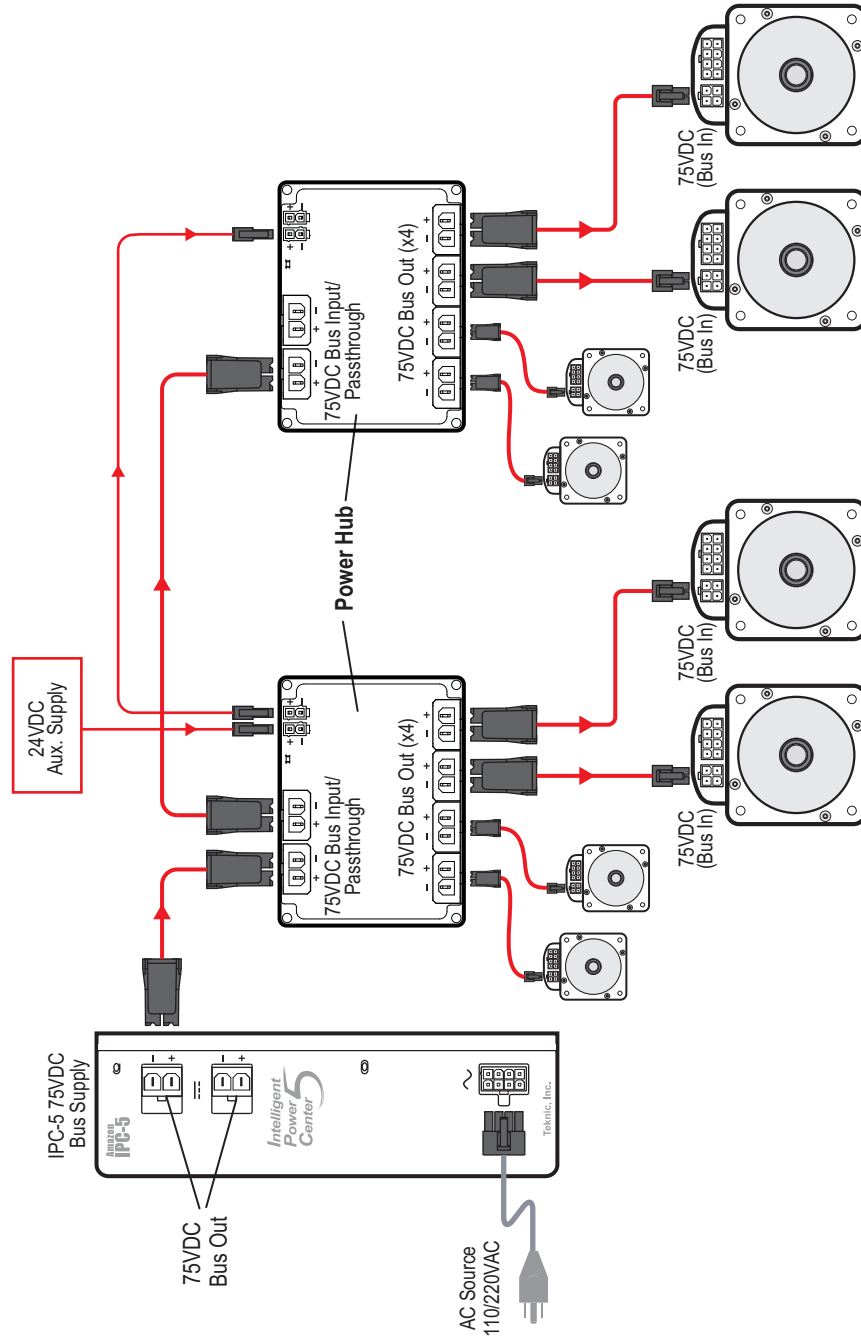

Two POWER4-HUBs powering 8 ClearPath-SC motors

AUXILIARY (24V) LOGIC POWER SUPPLY

The Power Hub and SC Hub each require 24VDC to function. (This is labeled as "24VDC Aux. Supply" in the above figure.) See the appendix "Sizing a Logic Power Supply" for power budgeting information. Note: Never use the main DC bus power supply (even if it happens to be 24VDC) for this purpose.

POWER4-HUB LEDs

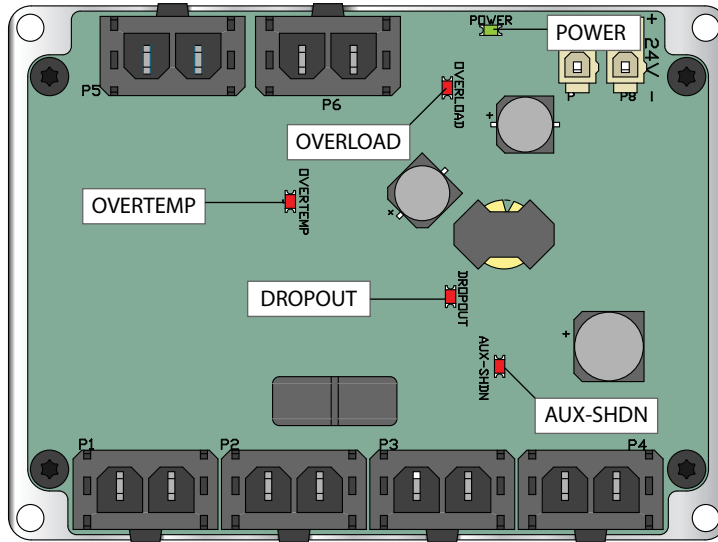

POWER4-HUB LEDs

LED Name	Color	LED On Indicates	LED Off Indicates
POWER <i>24V Power</i>	Green	Normal operation. Aux. 24V supply voltage detected.	Aux. 24V supply voltage not detected. Hub not functional.
OVERLOAD <i>Output Bus Overload</i>	Red	Short (or near short) circuit at bus output. Power Hub electronically disconnects bus input from bus output in this case as a protective measure.	Normal operation.
OVERTEMP <i>Board Thermal Shutdown</i>	Red	Board temperature has exceeded 105°C. (Note: After an overtemp event, LED will turn off when board temp falls below 95°C.)	Normal operation. (Board temp is < 105°C.)
DROPOUT <i>75V Dropout LED</i>	Red	Bus supply has "dropped out", meaning the DC Bus has fallen below 18.2 VDC. Aux. power is active.	Normal operation.
AUX-SHDN <i>Aux. Power Overload</i>	Red	Motor bus has dropped out and aux. supply is in an overloaded state. (The motor load has exceeded 1000mA for >20mS.) This is a latching shutdown. You must cycle the aux. power supply to clear.	Normal Operation

COMMUNICATION AND I/O (THE SC4-HUB)

INTRODUCTION

The SC Hub (Teknic part number *SC4-HUB*) is the center of communication and I/O routing for all ClearPath-SC systems. The SC Hub links the application computer and I/O devices to your ClearPath-SC motors. Up to four SC Hubs can be linked together to create systems of 16 motors on a single USB or RS-232 port. ClearPath-SC systems can support up to a maximum of 48 axes².

SC4-HUB OVERVIEW

The SC Hub interfaces with:

- Application PC
- ClearPath-SC motors
- Input sensors and switches
- Global Stop input
- Brake Control outputs

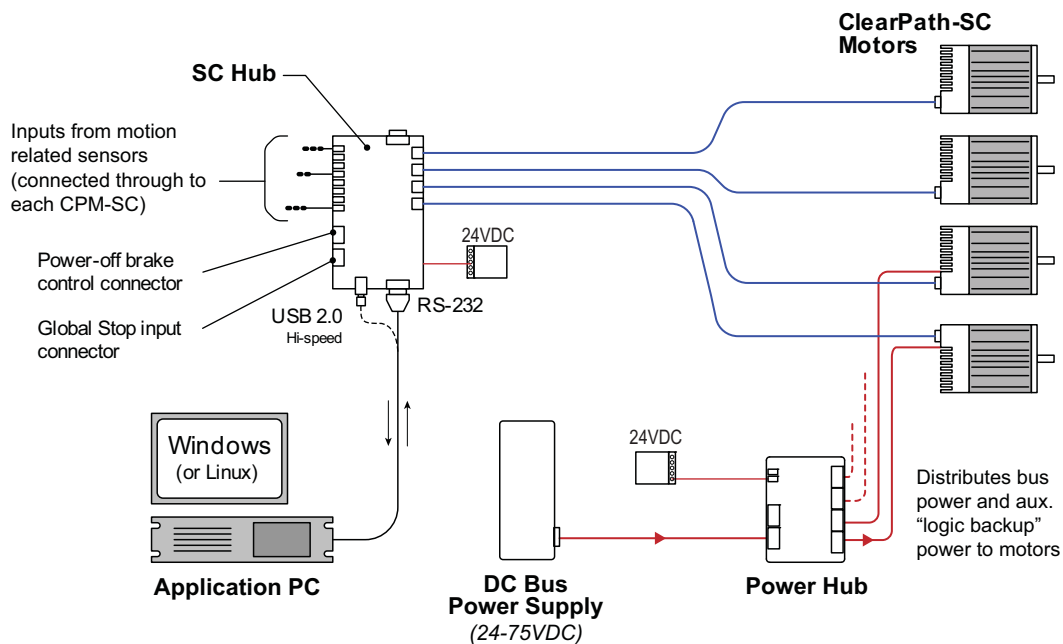

SC4-HUB in a 4-axis ClearPath-SC system

² To support a 48 axis system, the application PC must have a minimum of three USB or RS-232 ports.

PARTS OF AN SC4-HUB

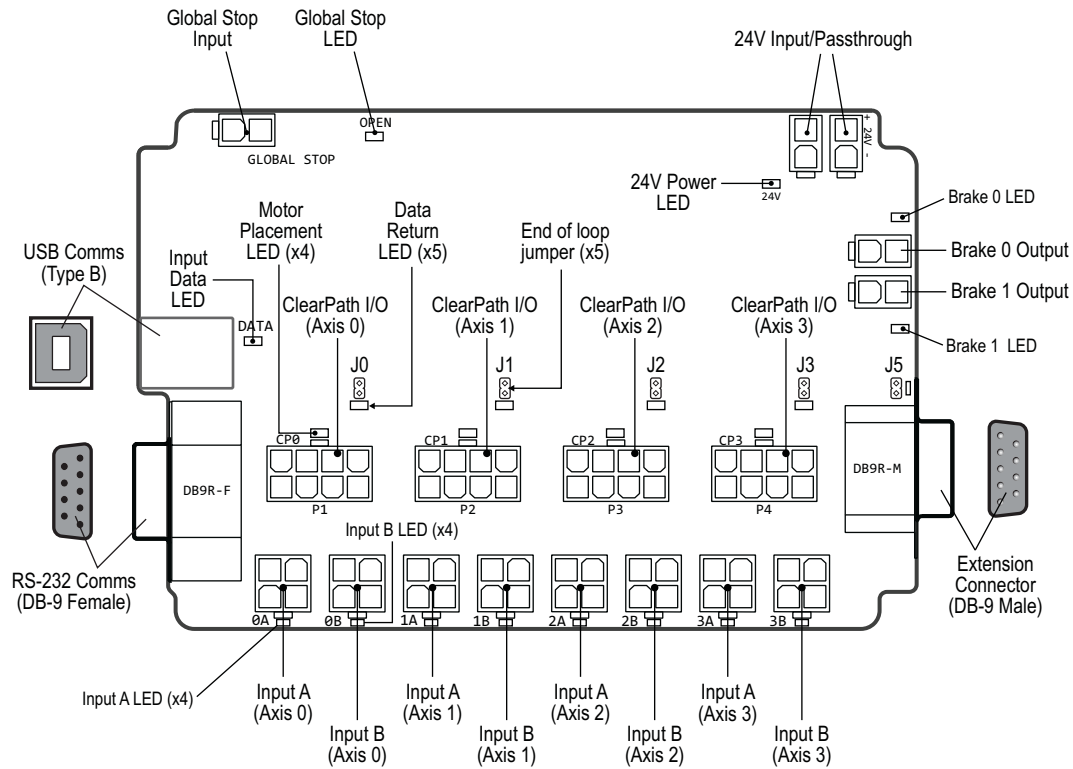

SC4-HUB with callouts

SC4-HUB MOUNTING

See [Appendix B, Mechanical Index](#), for SC Hub mechanical/mounting dimensions.

SC4-HUB OPERATION (CONNECTOR BY CONNECTOR)

24VDC INPUT / PASS-THROUGH CONNECTORS

Connection point for the (required) 24VDC logic power supply. There are a total of two 2-pin Molex connectors wired in parallel; you can supply power to either one. The second connector may be used to daisy chain power to another SC Hub or another 24VDC device if desired.

USB COMMUNICATION CONNECTOR (USB COMMS)

This is a standard USB type B connector. Connect SC Hub to your PC using a readily available cable (USB-B to USB-A).

Important: Never connect a USB and RS-232 connector to the same SC Hub. This will cause communication errors.

RS-232 COMMUNICATION CONNECTOR

The SC hub also has a high-speed RS-232 serial port built-in, so if you have an embedded host CPU without USB, you can use this instead. The DB-9 connectors also have the advantage that they can be positively locked by screwing them in.

This connector also serves as an data extension connector allowing users to chain multiple SC hubs together regardless of whether communication into the first SC Hub was USB or RS-232.

CLEARPATH I/O CONNECTOR

This connector sends communication and input signals from the SC Hub to the ClearPath-SC motor. The required cable is a straight-through, 8-pin to 8-pin Molex MiniFit Jr. cable (Teknic P/N: CPM-CABLE-CTRL-MU120).

END-OF-LOOP HEADERS

Place a jumper block on the 2-pin header associated with the last motor connected to your SC Hub. For example, if you are connecting just one motor to the SC Hub, place the jumper on J0. For two motors, place the jumper on J1. If you plan to connect a second SC Hub (for systems with five or more motors) place the jumper at J5, then on the second SC Hub place a jumper on the appropriate header.

INPUT A AND B CONNECTORS

Each ClearPath I/O connector on the SC Hub has two inputs associated with it: *Input A* and *Input B*. Each input has its own 4-pin Molex connector as shown below.

The inputs are designed for use with 24VDC,³ NPN type sensors or mechanical switches. The inputs are optically isolated, digitally filtered, current limited, and reverse polarity protected for robust, long-term performance. For more on how the inputs work, see the input circuit schematic (below) and Appendix G, *Wiring Inputs A and B*.

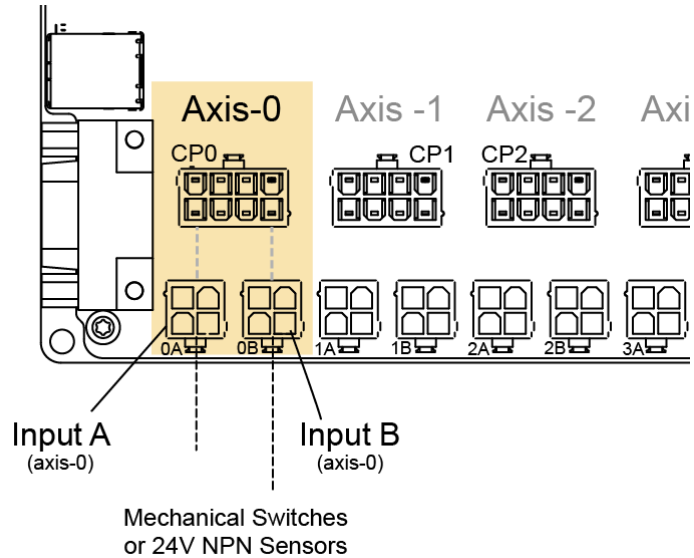

ClearPath-SC Input A and B Connectors

Maximum Input Cable Length

Cables used for SC inputs can be a maximum of 100 feet (30 m) long. However, longer cable runs may be possible if the cable stock is of high quality, low capacitance, twisted pair construction. Contact Teknic if you need input cables longer than 100 feet (30 m).

³ ClearPath -SC motors can accept inputs from devices with logic high ranging from 5-24VDC, but the SC Hub, by default, accepts 24VDC NPN type sensors or simple mechanical switches.

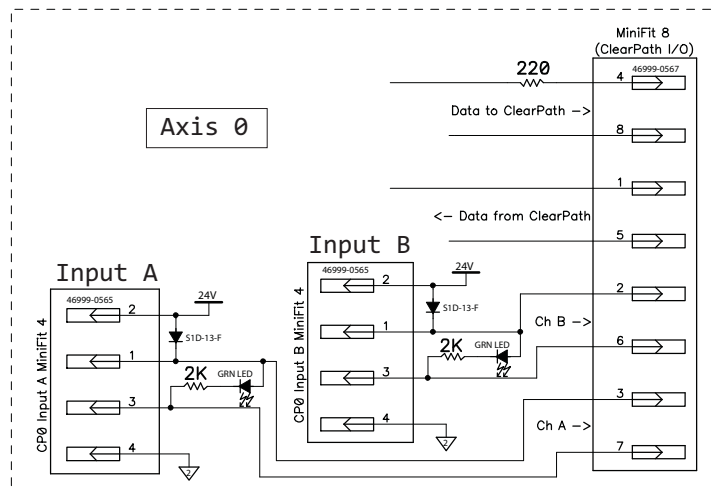

Schematic snippet: Input A and B

MINIMUM CURRENT REQUIREMENT

Input devices wired to ClearPath-SC inputs must be able to source/sink a minimum of 12mA.

Engineer’s Note: In all ClearPath-SC motors, the logic-level signals are electrically isolated from the DC power input and motor output circuits, as well as from the motor case to ensures that control signals are not compromised by induced currents from the motor, power supply, or PWM return path.

BRAKE CONTROL CONNECTORS

These two, 2-pin Molex Minifit Jr. connectors allow you to control "power-off" style 24VDC inline brakes. They can also be used as general purpose outputs (GPOs) to control any 24VDC device through your application code.

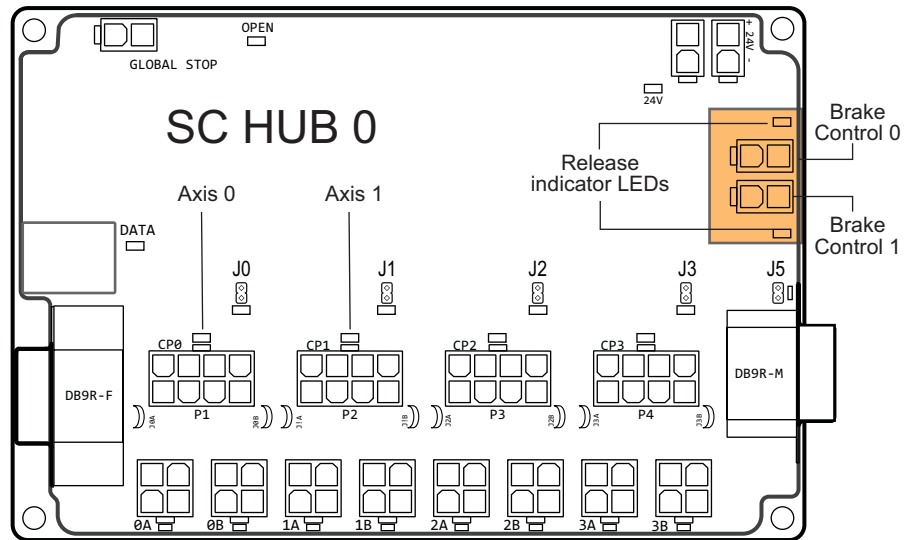

Brake Control Connectors

BRAKE BASICS

- Only two Brake Control outputs can be used *per port*. This means, if 4 SC Hubs are chained together and connected to a single USB or serial port, only the two brake outputs on the first SC Hub in the chain would be useable.
- Brake Control 0 and Brake Control 1 are linked to Axis 0 and Axis 1 respectively. This is a fixed, relationship.
- The Brake Control circuit was designed for use with 24VDC "power-off" type brakes that draw 500mA or less.
- Brakes will not release (allow motion) unless communication with a motor has been established.
- Brakes automatically engage (disallow motion) if communication with the Application PC is interrupted.

Engineer's Safety/Compliance Note: Depending on your machine application and safety compliance requirements (i.e. ISO 13849) external safety controls may be required when using this feature. The section "Safety Controls Concept Sketch" includes a high level safety system diagram for general reference.

BRAKE CONTROL CIRCUIT

The figure below shows a schematic fragment of one of the Brake Control circuits (Brake Control 0). See the Schematics appendix for complete SC Hub circuit drawings.

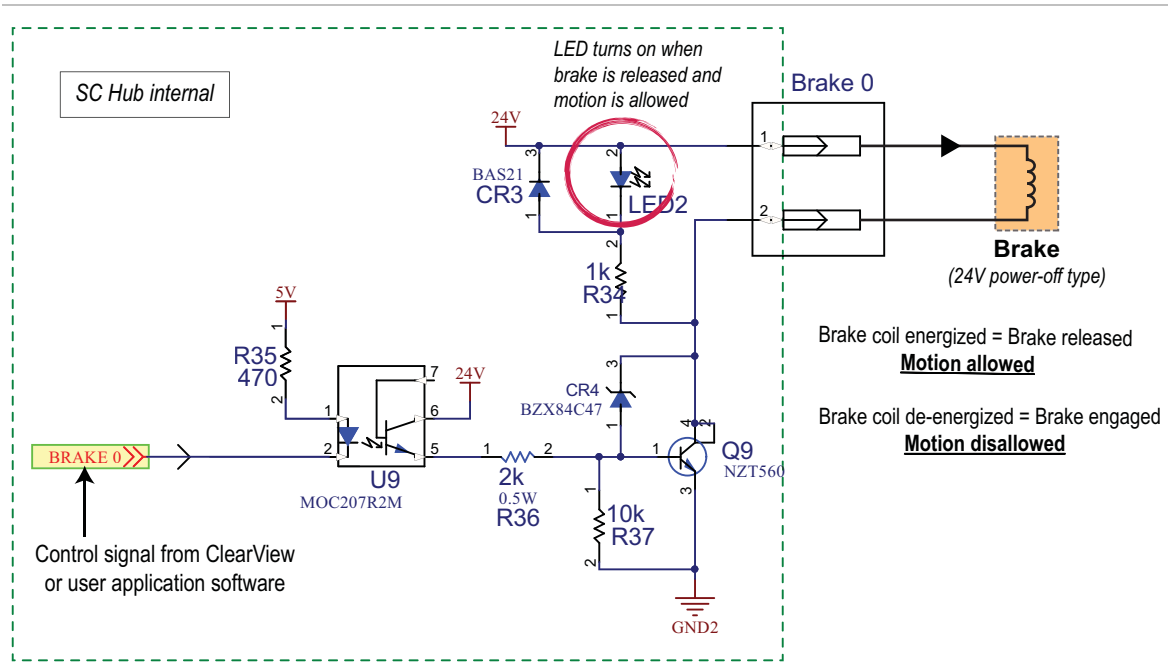

Schematic: Brake Control 0

CAUTION: BRAKE CONTROL SAFETY NOTE

In order to function, the brake control circuitry, by design, is accessible to the host operating system (e.g., Windows). Because of this, however, when your ClearPath-SC application code does not have control of the host's communication port (USB or serial), it is possible for the operating system to inadvertently release the brake. This can happen, for example, if the operating system scans its connected hardware (like during a port "auto-discover" function).

To eliminate inadvertent motion, your SC application should position all brake-fitted axes to their lowest potential energy state before exiting (i.e. before releasing the port back to the operating system). For example, position a vertical axis at the bottom of its motion range if it could otherwise fall when acted upon by gravity.

Whenever movement of any brake-fitted axis could result in a safety hazard, the brake outputs should be wired in series with an interlock switch circuit to all guard mechanisms preventing unsafe operator access, whether directly or through a safety controller. **Note: any safety circuit of this type must go open circuit when unsafe access is attempted to assure brake actuation.**

SETTING BRAKE CONTROL BEHAVIOR IN CLEARVIEW

The Brake Control outputs can be toggled manually or set to automatic operation through the ClearView Actions menu: *Actions>Brake 0*, or *Actions>Brake 1*.

Additional notes:

- Only two brake control outputs can be used per port connection; i.e. if four SC Hubs are chained together, only the two brake control outputs on the first SC Hub will be controllable.

GLOBAL STOP CONNECTOR

IMPORTANT: This is a software-based node stop control only. It is not a critical safety E-stop system.

This 2-pin Molex Minifit Jr. connector allows you to connect the E-Stop output from a safety controller to your SC Hub.

Engineer’s Safety/Compliance Note: Depending on your machine application and safety compliance requirements (i.e. ISO 13849) external safety controls may be required when using this feature. The section “Safety Controls Concept Sketch” includes a high level safety system diagram for general reference.

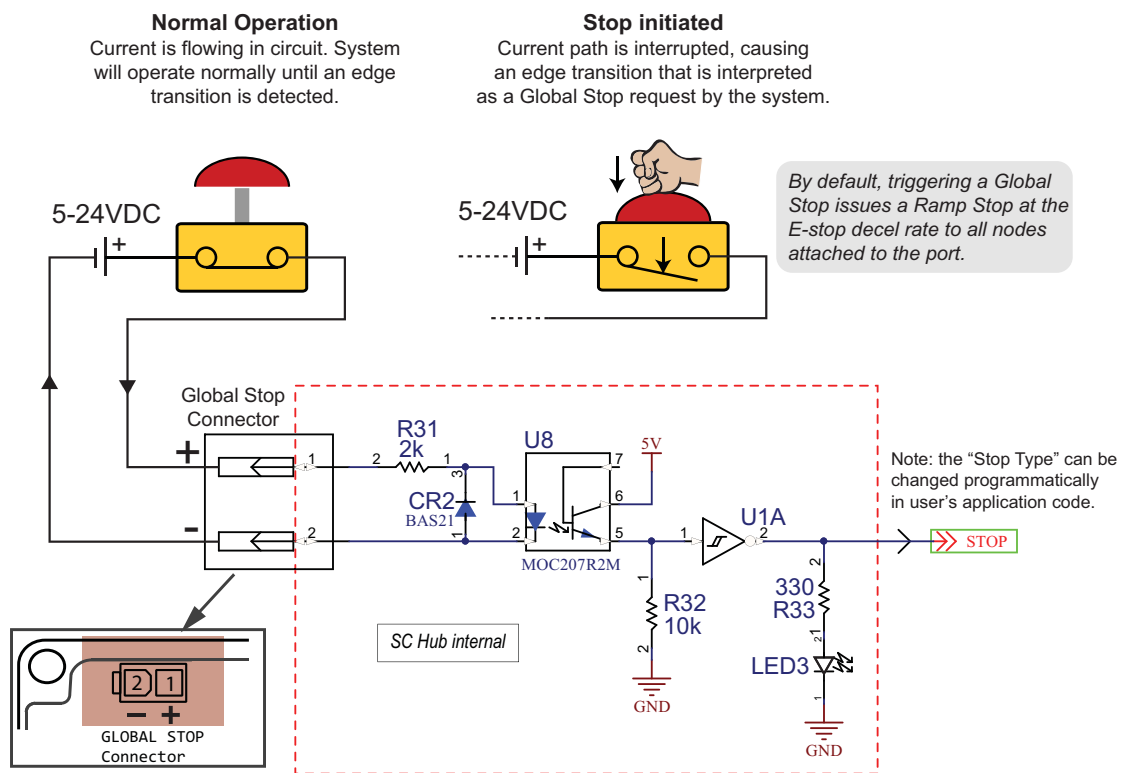

Schematic snippet: Global Stop Input

SAFETY CONTROLS CONCEPT SKETCH

The generic safety system sketch below is intended to provide a general idea as to how an engineer might approach the design of safety controls for a ClearPath-SC system⁴.

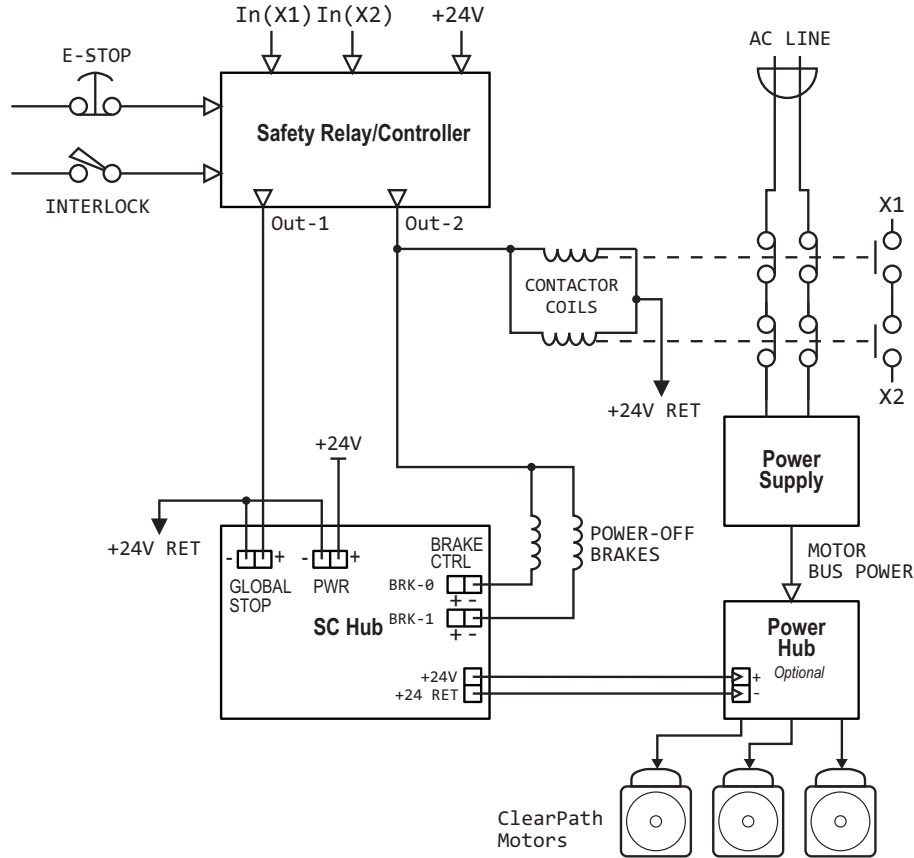

Safety system high level design concept

⁴ The figure above does not represent an existing, real world safety system for which parts have been sourced, prototypes built/tested, or formal documentation generated. As such, Teknic makes no representations as to the accuracy of this content, or suitability of this conceptual design for any purpose.

CONFIGURATION SOFTWARE (CLEARVIEW)

ClearView software provides a suite of powerful configuration, analysis, and diagnostic tools to speed machine *and* software development. These tools—the Soft Scope in particular—make it easy to capture valuable motion performance data whether you're in the lab, on the production floor, or in the field.

This section includes the following topics:

- PC system requirements
- Installing ClearView software
- Tour of ClearView software

MINIMUM SYSTEM REQUIREMENTS

Operating System:	Windows 10, 8.1, 7
Processor:	1.5 GHz or faster
Memory:	1 GB RAM
HD Free Space:	1 GB
Monitor:	1280 x 1024 pixels or higher
Other:	Sound card with speakers (optional)

INSTALLING CLEARVIEW SOFTWARE

- **Run Windows Update.** See note *Windows Update and ClearView* below.
- Download the ClearView installer from <https://www.teknic.com/downloads/>.
- Launch the ClearView installer. Follow on-screen prompts to complete installation.

Windows Update and ClearView Installation

If your Windows installation is not up to date, ClearView may not run properly. During installation, the ClearView installer needs access to a few specific Windows system files. If these files are not found, Windows Update will attempt to install them. If Windows Update is disabled, and/or you have no internet connection, this may fail.

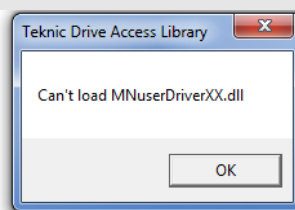

If you install and attempt to run ClearView and see an error window like the one shown above, close ClearView and install this update: <https://support.microsoft.com/en-us/kb/2999226>. Then, re-launch ClearView.

ESTABLISHING COMMUNICATION WITH YOUR SYSTEM

See ClearPath-SC Quick Start Guide.

CLEARVIEW SOFTWARE TOUR

USER INTERFACE OVERVIEW

The ClearView UI is presented in four parts: the *Menu*, *Manual Controls*, *Dashboard*, and *Soft Scope*. Each of these parts is discussed in detail in this section.

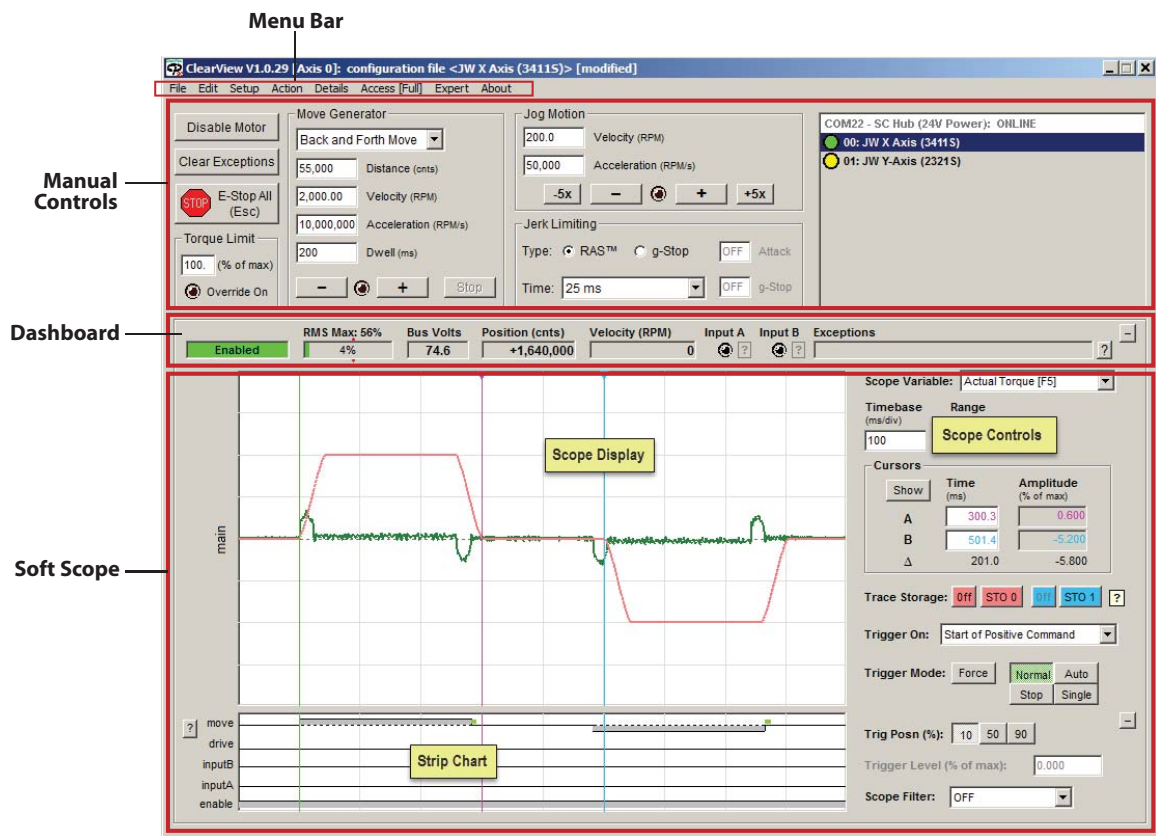

ClearView UI Overview

MANUAL MOTOR CONTROLS

The Manual Motor Controls comprise a set of tools designed to help you test and exercise your ClearPath-SC motors *without writing a single line of code*. Manual Controls give you the ability to:

- Enable, disable, and E-stop motors
- Manually jog motors
- Run profiled moves (reciprocating, single, or unidirectional repeating)
- Modify the torque limit setting, and more

The screenshot shows the Manual Motor Controls interface with several callouts:

- Enable/Disable:** Click to enable the active motor, click again to disable.
- Move Parameters:** Set desired velocity, acceleration, etc. for Move Generator.
- Jog CW:** Click and hold to jog clockwise.
- Fast Jog:** Click and hold to jog CCW at 5x the jog velocity.
- Motor Selector:** Click a motor in this list to make it the current "Active Motor".
- COM22 - SC Hub (24V Pow):**
 - 00: JW X Axis (3411S)
 - 01: JW Y-Axis (2321S)
- Global Torque Limit:** 100. (% of max)
- E-stop Button:** Click to immediately E-stop all motors on the current port.
- Stop Move:** Single click stops motion only after move completion. Double click stops move immediately.
- Jerk Limit / g-Stop Controls:** Note: g-Stop not available on all CPMSC models.

The interface includes sections for:

- Disable Motor** and **Clear Exceptions** buttons.
- E-Stop All (Esc)** button with a red stop sign icon.
- Torque Limit** section with a slider set to 100.0 and an **Override On** button.
- Move Generator** section with a dropdown menu set to "Back and Forth Move" and input fields for Distance (30,000), Velocity (2,000.00), Acceleration (10,000,000), and Dwell (200).
- Jog Motion** section with input fields for Velocity (200.0) and Acceleration (50,000), and buttons for -5x, -, +, and +5x.
- Jerk Limiting** section with Type set to RAS™, g-Stop OFF, and Time set to 16 ms.
- Start Move** buttons (-, +, Stop).

Manual Controls section of ClearView UI

DASHBOARD

The Dashboard features virtual indicators and readouts for motor status, encoder position, motor velocity, bus voltage, input states, exception messages, and more.

Motor/Drive Status
(Tip: double click to clear exceptions).

RMS Meter
Displays real-time (and maximum recorded) RMS motor current. ClearPath shuts down if RMS reaches 100%, to prevent burnout.

Exception Information
Click here to open a dialog box containing additional information on any active exception or shutdown.

DC Bus Voltage

Position Counter
Displays position of motor shaft in encoder counts.

Velocity Meter
Displays motor shaft velocity in kcounts/sec or RPM.

Input A and B Status LEDs
LED on = Input asserted
LED off = Input de-asserted

Exception Messages
Displays a brief message related to any active ClearPath exception.

Motor Status	Description
Enabled	Motor is enabled. Caution: Motor is energized and capable of motion.
Disabled	Motor is disabled. Motor coils are not energized.
Shutdown	ClearPath is in a shutdown state. Motor coils are not energized.
Dynamic Brake	A "disabling type" node stop was issued. Example: STOP_TYPE_DISABLE_ABRUPT Motor coils are not energized.
Move Lock	An E-stop was issued. Motor coils are not energized.
Brake+MvLock	An "E-stop and disabling type" node stop was issued. Example: STOP_TYPE_ESTOP_DISABLE_ABRUPT Motor coils are not energized.
No Comm	ClearPath is connected to a PC but not powered up. (This may indicate low or no DC Bus power.)
Unconnected	No motors were detected by ClearView.

Dashboard section of ClearView UI

SOFT SCOPE

OVERVIEW

The ClearView Soft Scope takes real-time streaming data from your ClearPath-SC motor and plots it on a scope display in an intuitive, easy-to-interpret manner. The Soft Scope can display your motor's *actual torque output, position error, commanded velocity, acceleration*, and more. This is a great tool for engineers, technicians, or maintenance professionals tasked with the analysis or troubleshooting of motors, motion, and mechanical performance.

The Soft Scope consists of three main sections: the **Scope Display (1)**, **Strip Chart (2)**, and **Scope Controls (3)**. Together, these components emulate much of the functionality of a digital storage oscilloscope and data analyzer.

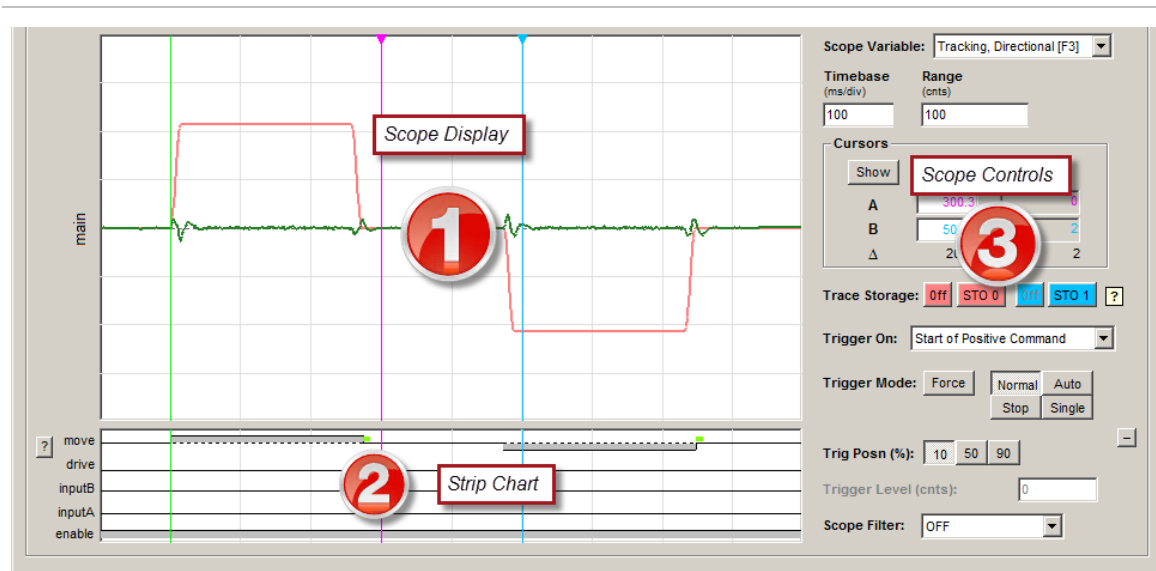

ClearView Soft Scope

SOFT SCOPE FEATURES

- 13 scope variables that can be plotted in real time
- Four trigger modes
- Adjustable timebase, range, and trigger position
- Simultaneously display two stored traces + one live trace
- 13 trigger presets (Example: trigger at end of settled move)
- Interactive cursors for precise timing and amplitude measurements
- Strip Charts for a consolidated view of motor status, input states, and move timing

SCOPE DISPLAY AND SCOPE CONTROLS

The ClearView Scope display is modeled after a typical hardware oscilloscope. It has 10 major vertical divisions (the time axis), and 8 major horizontal divisions (the amplitude axis).

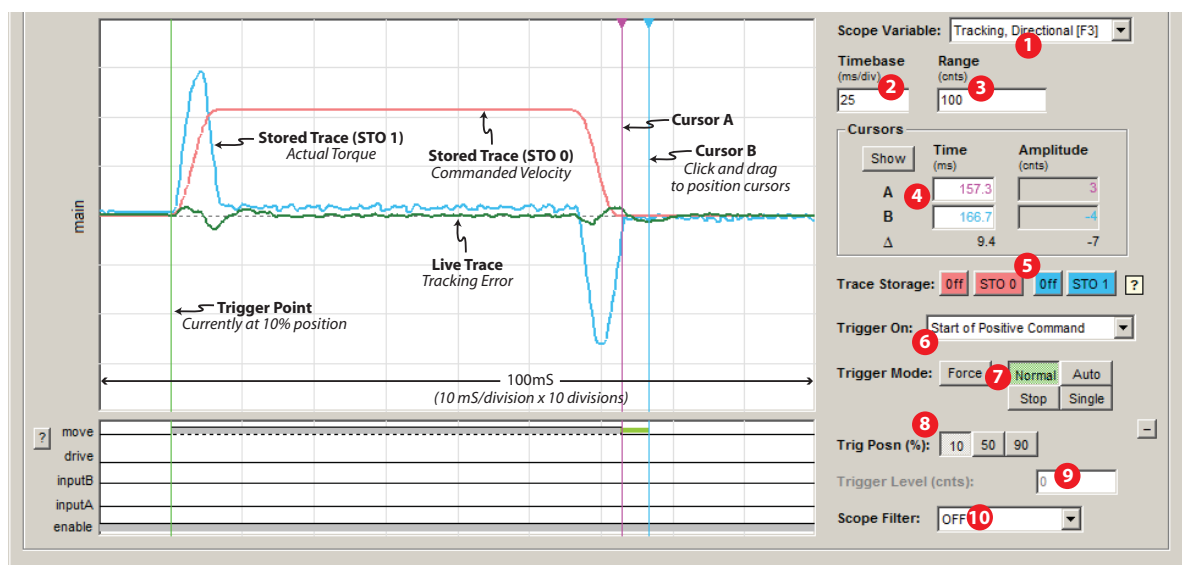

ClearView Soft Scope

1 The Scope Variable drop down menu lets you select any of 13 ClearPath-SC motion control variables to display. These variables are Tracking Error, Commanded Velocity, Actual Torque, Actual Velocity, Velocity Error, Commanded Torque, SGN (sign of velocity), Measured Position, Commanded Jerk, Commanded Acceleration, Max Phase Voltage, Torque Error (peak), and Bus Voltage.

2 The Timebase field lets you adjust the scale of the time axis (think X-axis) in units of mS/division. This allows you to control how a waveform fits horizontally on the Scope Display.

Example: With the Timebase set to 10mS per division (as in the figure above) the full horizontal range of the Scope Display is 100mS (10 divisions x 10mS/division).

3 The Range field lets you adjust the scale of the amplitude axis (think Y-axis). This allows you to control how a waveform fits vertically on the Scope Display.

Example: In the figure above, the green "live" trace represents the motor's tracking error (i.e. how close is the actual motor position to the commanded position). The Range is set to 100 counts.

To interpret the displayed information, you only need to understand a few things: 1) the center horizontal line represents 0 counts of tracking error (perfect tracking), 2) the top of the Scope Display represents +100 counts of tracking error, and 3) the bottom of the scope display represents -100 counts of tracking error. The +/- distinction is necessary because the actual motor position can lead *or* lag the commanded position. By doing a little math you will find that each major horizontal division represents 25 counts of error.

4 Cursor controls display time and amplitude measurements of the live trace. Note: the time readout for the cursors is referenced to the Trigger Point (that's where t = 0). Amplitude is measured relative to the horizontal center line. The delta (Δ) function automatically displays the difference between the two cursor values. Click and drag cursors to reposition them. Click the *Show* button to make cursors appear if they are hidden.

5 Trace Storage controls let you save and display two traces on the scope display. Just capture a waveform and click either the STO 0 or STO 1 button (Storage 0 and Storage 1). The selected trace is then stored and displayed in either pink (STO 0) or blue (STO 1). Hide or show either stored trace by clicking its respective On/Off button.

6 The Trigger Source (“Trigger On”) menu lets you choose what conditions must be met before scope data collection begins (is triggered). The following Trigger Source options are available:

If Trigger Source is set to:	MSP Scope will:
Start of Positive Command	Trigger at the start of any positive move; useful for tuning.
Start of Negative Command	Trigger at the start of any negative move; useful for tuning.
Start of Any Command	Trigger at the start of any move (positive or negative); useful for assessing bi-directional tuning performance.
End of Positive Command	Trigger at the end of any positive move; useful for assessing settling performance.
End of Negative Command	Trigger at the end of any negative move; useful for assessing settling performance.
End of Any Command	Trigger at the end of any move (positive or negative); useful for assessing bi-directional settling.
End of Positive Settled Move	Trigger at the end of any positive move after Move Done criteria are met; useful for assessing settling performance.
End of Negative Settled Move	Trigger at the end of any negative move after Move Done criteria are met; useful for assessing settling performance.
End of Any Settled Move	Trigger at the end of any move (positive or negative) after Move Done criteria are met; useful for assessing settling performance.
Voltage/Torque/Speed Limit	Trigger on first occurrence of saturation (voltage or torque) or upon speed limiting; useful for determining which moves (or segments of moves) exceed these thresholds.
Drive Shutdown or Exception	Trigger on the assertion of an exception or safety shutdown; useful for determining the operational status at the time of a fault.
Rising Slope	Trigger on the rising edge of the active waveform.
Falling Slope	Trigger on the falling edge of the active waveform.

7 Trigger Mode settings allow you to select exactly when data acquisition begins and ends. These controls are similar to the trigger modes found on typical digital storage oscilloscopes.

- **Normal** - Causes scope data collection to begin whenever a valid trigger source is detected.
- **Single** - Works the same as *Normal* mode, except it captures only a single data set when a valid trigger source is detected. After the single sweep capture, data collection automatically stops.
- **Auto** - This is the rolling, “always on” setting. Data is continuously collected, refreshed, and displayed regardless of the trigger source settings.
- **Force** - Forces the scope to trigger immediately, regardless of trigger source setting. As with Single mode, only one data set is collected and displayed; then data collection stops.
- **Stop** - Causes scope data collection to stop. It does *not* clear previously captured data from the scope display.

8 Trigger Position buttons allow you to position the trigger point on the left (10% position, as shown in the previous figure), middle (50% position), or on the right side (90% position) of the scope display grid. This is useful for viewing events on the scope that occur before, during, or after the trigger point.

9 The Trigger Level lets you select the amplitude at which the scope will trigger.

Note: Trigger Level can only be used when Trigger Source is set to “Rising Slope” or “Falling Slope”.

Tip: Use Trigger Level when the Trigger Mode is set to “Normal” or “Single” to facilitate waveform display at a fixed trigger point.

10 The Scope Filter “cleans up” or smoothes the appearance of the displayed trace by removing higher frequency data content. This has an averaging effect on the displayed waveform that can help mitigate the effect of noise (or just remove visual clutter) on the displayed signal.

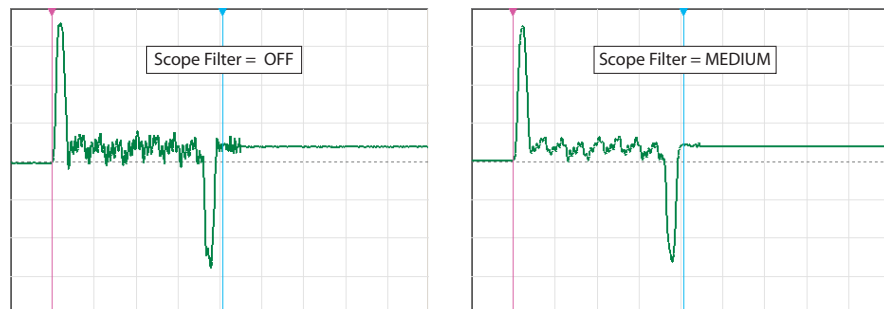

Effect of Scope Filter on trace display

Note: The Scope Filter has no effect on motor performance. *It changes only how scope data is displayed.*

Note: Higher filter setting may filter out meaningful data points from the display (peaks in particular).

Tip: In most cases Scope Filter can be left “OFF” or at the lowest setting.

STRIP CHART

The Strip Chart provides a visual overview of your motor status, input states, and motion performance. A quick look at the strip chart can tell you if the motor is enabled, shut down, hit a limit, whether the inputs are asserted or not. And, because the Strip Chart display is always in sync with the main scope trace, there's no extra setup required.

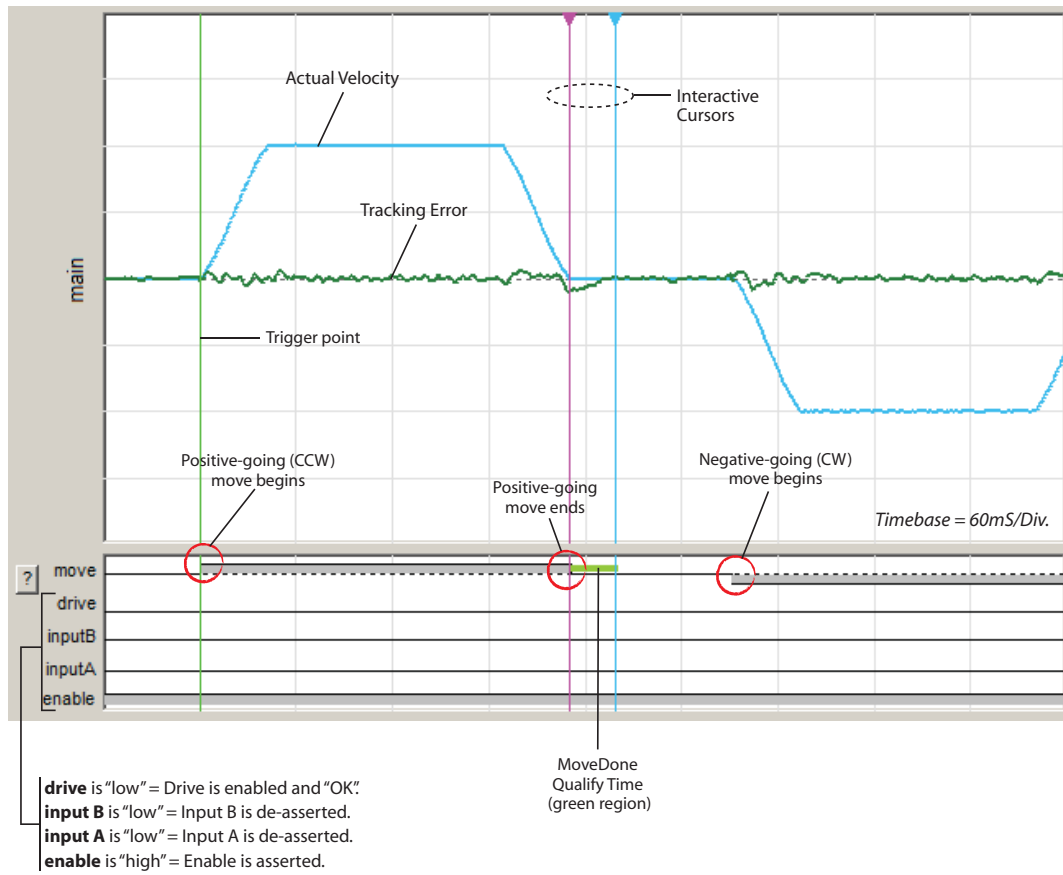

ClearView Strip Chart display

Strip Chart Legend

This key explains the strip chart trace colors and symbols. Click the  symbol to the left of the strip chart display to open.

CLEARVIEW MENUS

This section covers the ClearView menu bar and menu items.

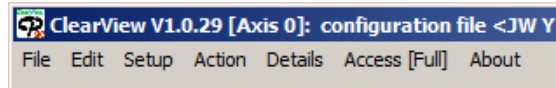

ClearView Menu Bar

FILE MENU

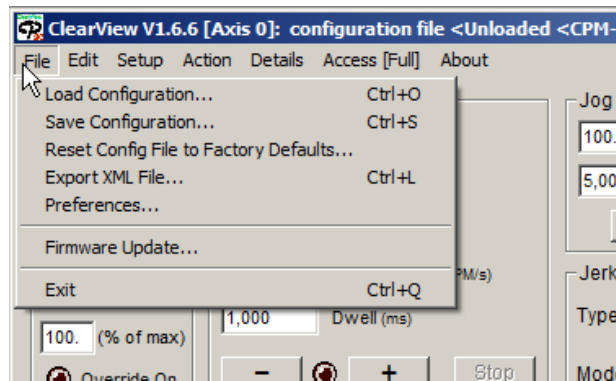

ClearView File Menu

Load Configuration (Ctrl+O)

Allows you to load motor configuration files to your ClearPath-SC motors. The file extension is mtr.

Save Configuration (Ctrl+S)

Allows you to save your ClearPath-SC configuration settings to your PC as a .mtr file.

Reset Config File to Factory Defaults

Restores ClearPath-SC to its factory default configuration (i.e., the way it was configured when you received it). All existing settings will be overwritten. Save your current configuration as a .mtr file (described above) if you think you'll need to use it some other time.

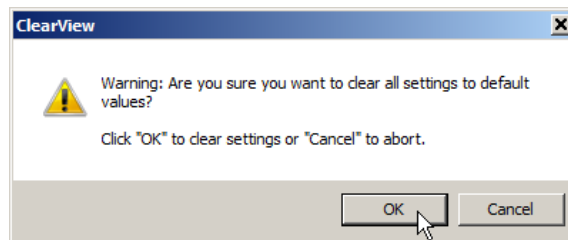

Export XML File

Beta feature for Teknic internal use at this time.

Preferences

Opens a dialog that lets you manage COM port settings and event sounds in ClearView.

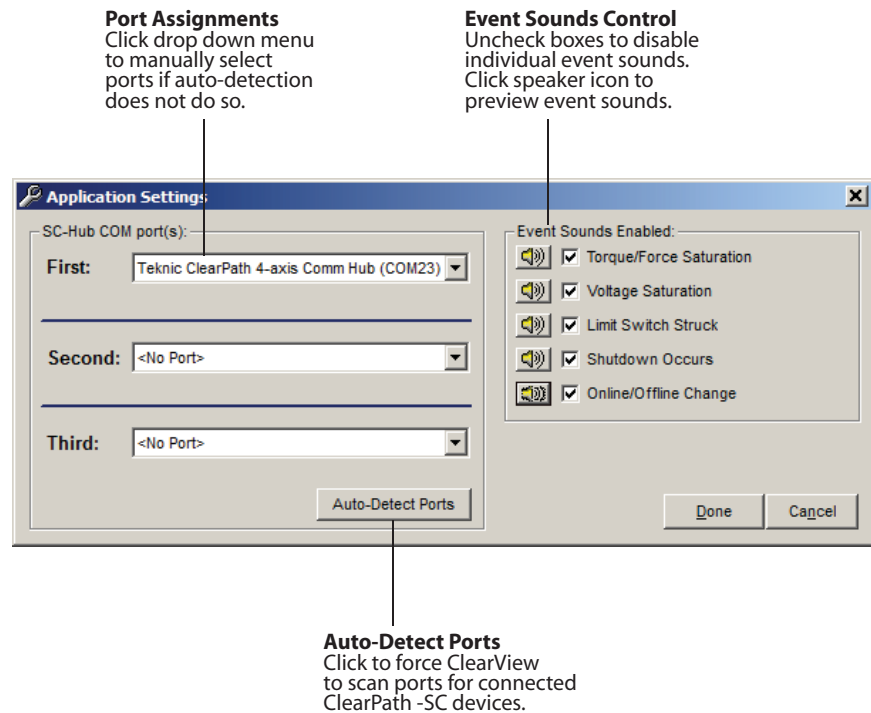

Preferences

Firmware Update

Allows for field update of ClearPath firmware.

EDIT MENU

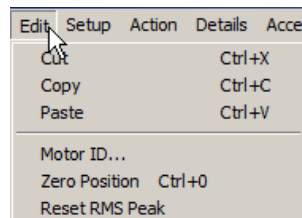

ClearView Edit Menu

Cut, Copy, Paste

These are just standard Windows commands and keyboard shortcuts.

Motor ID

Select this menu item to open a window as shown below. There you can enter a customized name for your motor. There's also space to enter additional notes on the system. Text entered will remain in your motor's non-volatile memory even when all power is removed.

Motor Identity Setup

Motor Name
This is a user-defined name for the motor (up to 25 characters) that is shown in the main MSP title bar.
For example, "Titan x-axis".
JW X Axis (3411S)

Mechanical System Description
This description identifies what was connected to the motor when it was auto-tuned. This allows you to recognize if the mechanics have been changed since the auto-tuning procedure.
For example, "Ballscrew: 1m long, 15mm dia., 5mm pitch. Load mass, 10kg. Bearing wiper removed. Medium cable track."
Available characters = 95
Enter useful information here

Verify Tuning Upon Connection
By default, upon USB connection, ClearPath MSP will remind you to start the auto-tuning process if the mechanics have changed since the motor was last auto-tuned. To prevent this reminder from appearing for this serial number motor, check the box below.
 will remember to re-tune if the mechanical system changes. Do not ask again for this motor.

OK Cancel

ClearView Motor ID Window

Zero Position (Ctrl+o) <-- that's a zero

Click or use keyboard shortcut Ctrl-o to zero the Position Counter on the ClearView Dashboard.

Tip: You can also zero the Position Counter by simply double-clicking it directly on the Dashboard.

Reset RMS Peak

Click to set value of *RMS Max* to the current RMS value. (This applies to the RMS Meter in the Dashboard section of ClearView.)

SETUP MENU

The Setup Menu provides a simple, no code required, way to manage frequently used motion control actions and events such as input behaviors, homing, torque limiting, software limits, Auto-tune, and more.

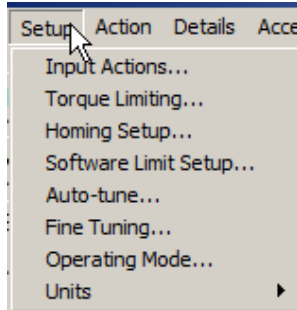

Input Actions

The upper section of the window lets you select one or more actions to execute when a state change is detected at Input A or B.

The lower section of the window lets you specify precisely when to trigger an encoder position capture.

Note: The Position Capture feature is always enabled; it can be simply disregarded if not used.

Note: Input A captures encoder positions at 0.1 microsecond resolution; Input B captures at 300 microsecond resolution. These values are not adjustable.

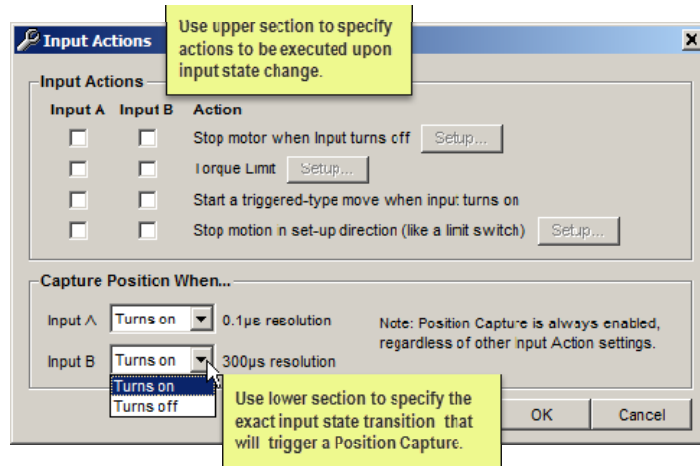

Input Actions Setup

Torque Limiting Setup

This menu item brings up a selection of conditional torque limiting options (see figure below).

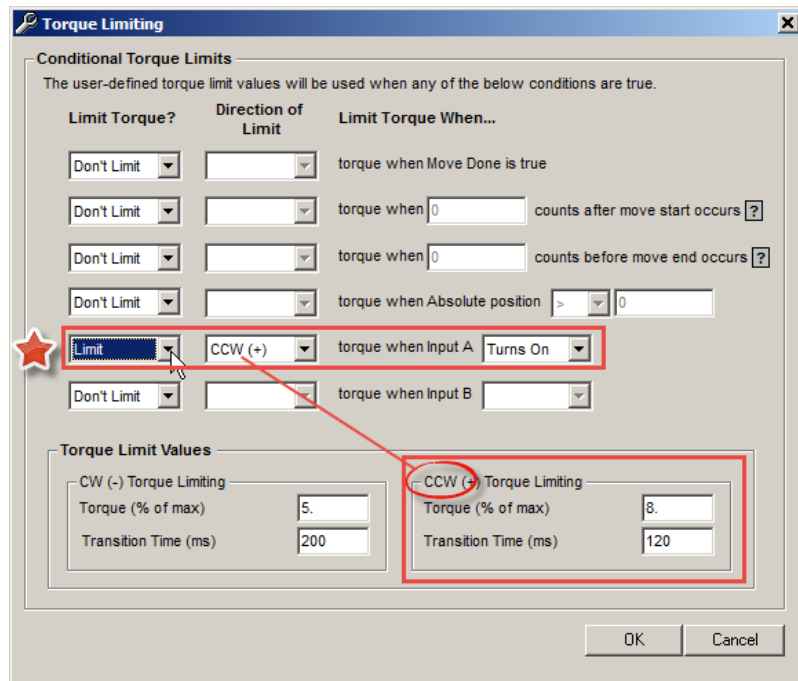

Torque Limiting Setup

Example: the above conditional statement (indicated with a red star) reads: *Limit CCW(+) torque when Input A turns on.*

The "long form" translation is this: *When Input A turns on, institute a torque limit in the CCW (+) direction of 8% of the motor's maximum peak torque capability. Transition from the current torque limit to the 8% torque limit over 120 mS from the time Input A turns on.*

Homing Setup

The Homing Setup dialog lets you quickly set up frequently used homing parameters without the need to code them into your application software.

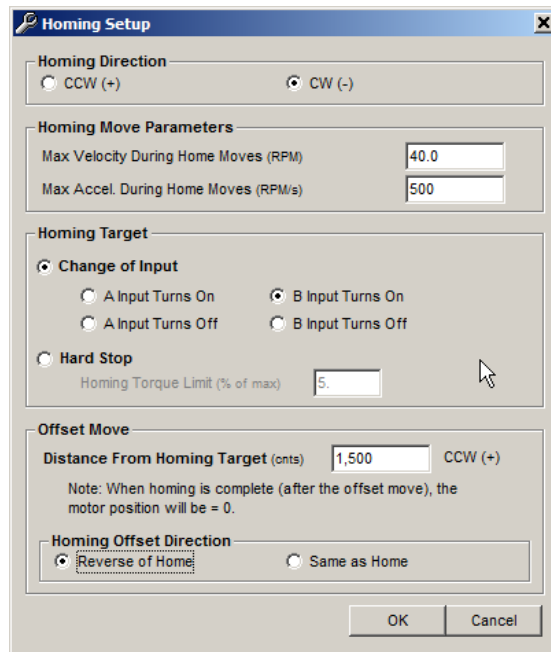

Homing Setup

Software Limit Setup

This feature lets you define travel limits in terms of encoder position, with no sensors or switches required.

To use this feature, Check *Enable Software Limits* and set the two encoder positions as desired.

Note: Software Limits do not take effect until the motor is homed.

Note: When Software Limits are activated, the motor will not execute any move that would violate the Software Limit settings.

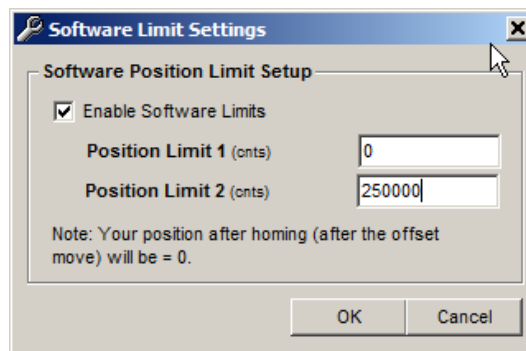

Software Limit Setup

Auto-Tune

Select this menu item to begin an Auto-Tuning session. The software is designed to walk you through the Auto-Tune process in a safe, step-by-step manner.

Important: Avoid personal injuries, crashes and machine damage. Carefully read and follow all instructions presented during the Auto-Tune process.

Fine Tuning

This menu item provides a convenient way to "touch up" tuning performance. Turn on the control by checking *Apply Fine Tuning*. Move the slider left for quieter performance, move it right for increased dynamic stiffness. Uncheck to turn it off.

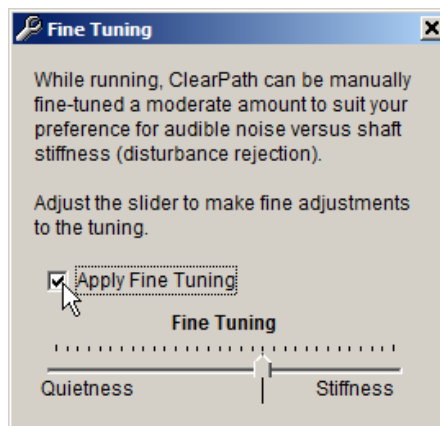

Fine Tuning Setup

Operating Mode

This dialog lets you choose (from three available options) how you will command motion, whether it's through **software motion commands** (more common), or by using an external **step and direction** pulse source, or by using an external **quadrature A/B** pulse source.

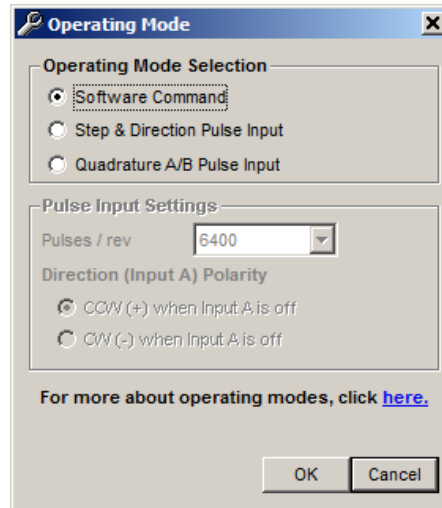

Operating Mode Dialog

Software Command

Select *Software Command* if you intend to command motor motion using only your application software and motion functions in the Teknic sFoundation library. This is the default setting and most common operating mode used with SC family motors.

Step and Direction Pulse Input

Select *Step and Direction* if you plan to use an external step and direction pulse source (PLC, microcontroller, etc.), and you intend to build a machine application and use other functions in the sFoundation motion library.

Quadrature A/B Pulse Input

Select *Quadrature A/B Pulse Input* if you have an external quadrature A/B pulse source (PLC, microcontroller, etc.) and you intend to build a machine application and use other functions in the sFoundation motion library.

Units

Use this menu item to tell ClearView which units to display for velocity and acceleration. Velocity and acceleration can express in terms of encoder counts or RPM. Distances are always displayed in encoder counts.

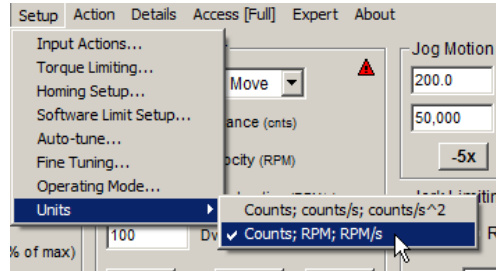

Units Setup

ACTION MENU

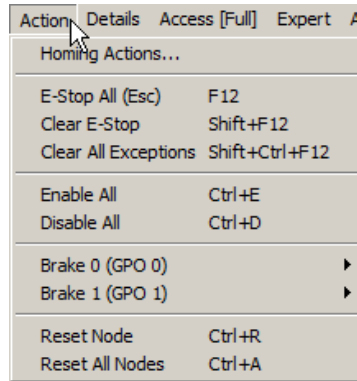

Action Menu

Homing Actions

This menu item provides access to several homing controls, parameters, and homing status indicators. Use these controls to simulate, test, and refine your homing routine without writing code.

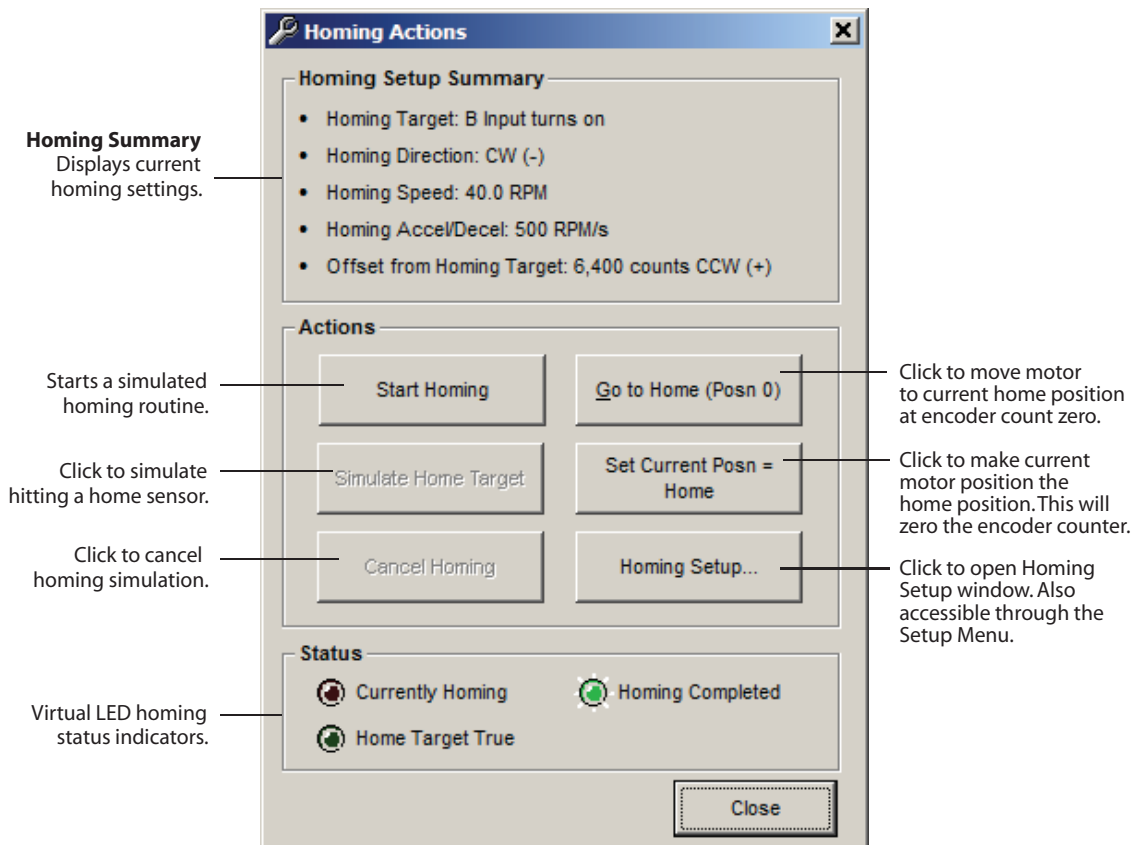

Homing Actions

E-Stop All (Esc or F12)

Issues an E-stop (node stop) to all ClearPath-SC motors on the port.

Clear E-Stop (Shift+F12)

Clears E-stop and returns motors to previous operating states.

Clear All Exceptions (Shift+Ctrl+F12)

Clears exception state and messages. Note: The exception condition may recur if the underlying cause of the exception still exists.

Enable All

Caution: selecting this control will immediately energize all motors on the port. Always treat an enabled motor as if it can move at any moment.

Disable All

Disables all motors on the port.

Brake 0 and Brake 1

Opens a submenu that lets you manually or automatically control the state of a 24V inline brake (or other compatible device).

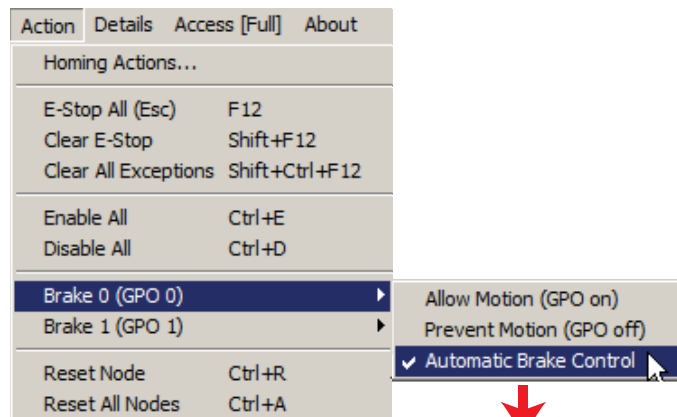
**Allow Motion (GPO on)**

Turns on the output. When selected, current is allowed to flow in the brake circuit. This would cause a power-on type brake to release (allow motion). External power required.

Prevent Motion (GPO off)

Turns the output off. When selected, current flow is inhibited in the brake circuit. This would cause a power-on type brake to clamp (disallow motion).

Automatic Brake Control

Automatically turns the output on (allows motion) when motor is enabled, and turns the output off (prevents motion) when the motor is disabled.

Brake Actions**Reset Node (Ctrl+r)**

Resets the currently selected motor.

Reset All Nodes (Ctrl+a)

Resets all motors on the port.

DETAILS MENU

The Details Menu provides access to setup dialogs for the ClearPath-SC features listed below:

- Tracking error limit
- Move status indicators
- Input filtering
- Deceleration rate for E-stops
- Vector Regen Shunt (VRS)
- Actions upon disable
- Power and temperature settings

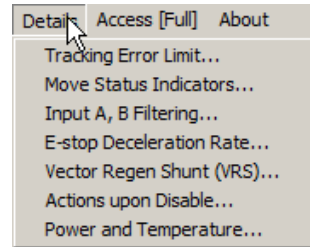

Please read the dialog boxes below to learn more about each feature and its settings.

Tracking Error Limit Setup

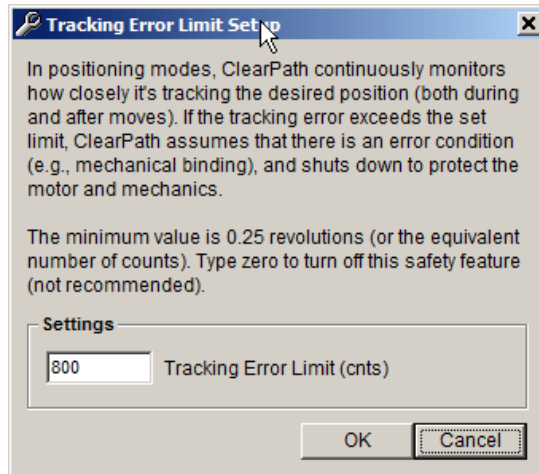

Input A, B Filtering Setup

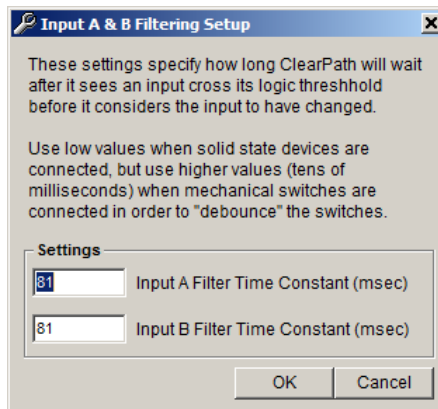

Move Status Indicators Setup

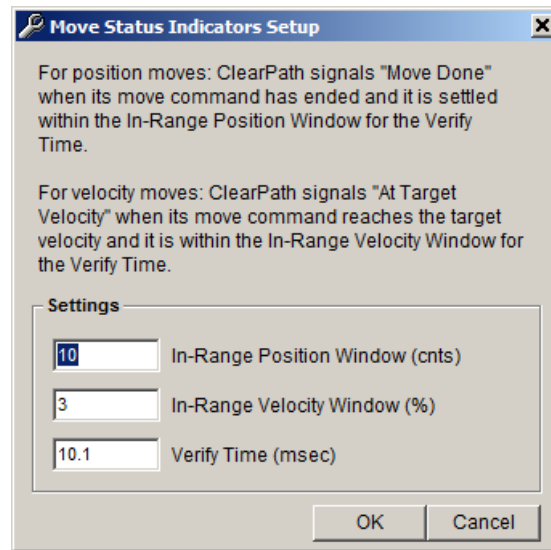

E-Stop Deceleration Rate Setup

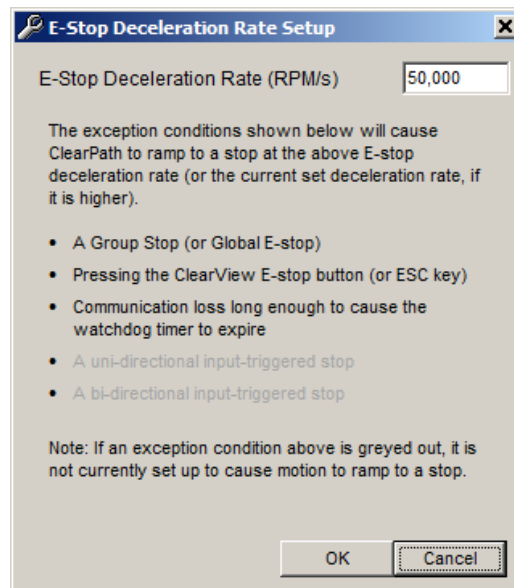

Vector Regen Shunt (VRS)

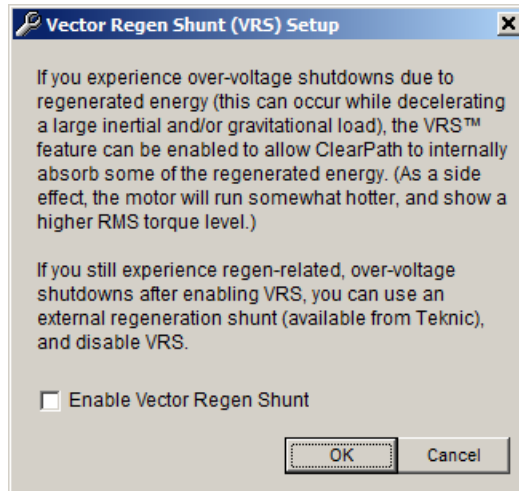

Actions Upon Disable

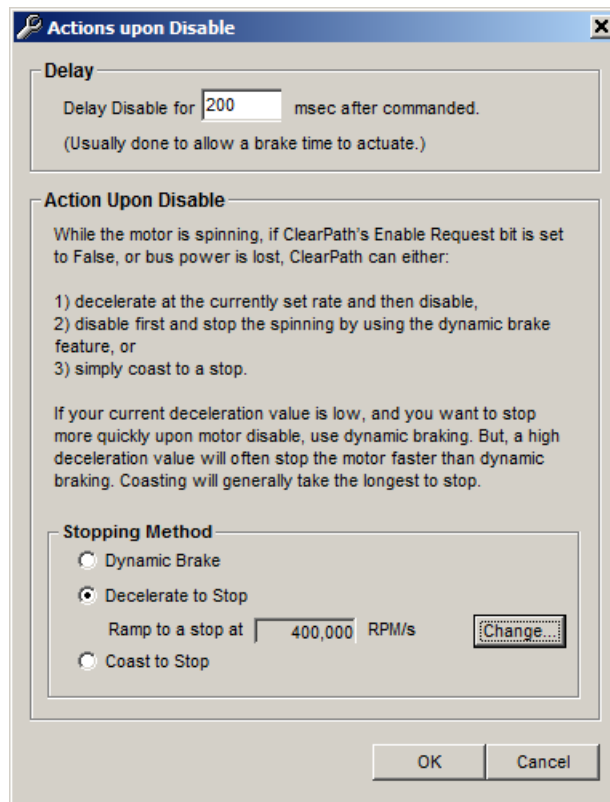

Power and Temperature

Power and Temperature Settings and Status [X]

Measured Bus Voltage (VDC): 74.9 Power Source: DC

Status	Power Exception	Exception Type
<input checked="" type="radio"/>	Bus went below the minimum operating bus voltage	<input checked="" type="radio"/> Shutdown <input type="radio"/> Warning
<input checked="" type="radio"/>	Bus Voltage Overload	<input checked="" type="radio"/> Shutdown only

Minimum Operating Bus Voltage

Minimum operating bus voltage (VDC)

Drive Temperature (°C)

Measured	Maximum
<input type="text" value="41"/>	<input type="text" value="83"/>

ACCESS MENU

A second computer (or a second port on the same computer) can be connected to your ClearPath-SC via the rear Diagnostic Port. The **Access Menu** lets you specify which of the ports has full control of the motor (only one can).

There are three Access modes. Please see the next section, "Using the Diagnostic Channel", for details on

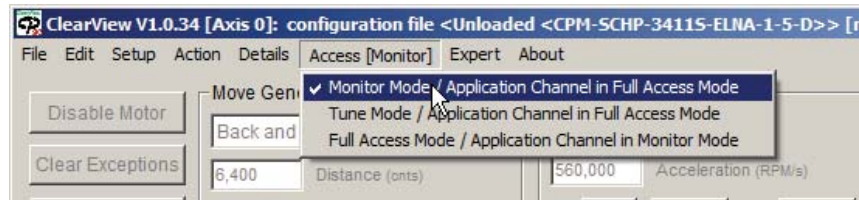

Access Menu

USING THE DIAGNOSTIC CHANNEL

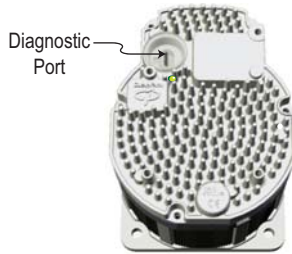

This section describes how to access and use the Diagnostic Channel of your ClearPath-SC motor.

The Diagnostic Channel is accessed via a USB port located on the back of your motor. It is another way to communicate with your ClearPath motor.

The great benefit of the Diagnostic Channel is that it allows you to run your machine software on the "main" channel (aka, the Application Channel) while simultaneously monitoring performance on the Diagnostic Channel.

TERMS USED IN THIS SECTION

Application Channel. This is the primary communication channel between the Application Computer and ClearPath-SC motor(s). See blue data path in figure below.

Application Computer. This is the PC that runs the machine application software (written by the user).

Diagnostic Channel. This is a secondary data channel that sends data between the ClearPath-SC and either a different port on the Application Computer or a separate PC altogether. The Diagnostic Channel is accessed via the USB Diagnostic Port on the back of the motor.

Note: ClearView *and* your machine application cannot run on the same channel simultaneously. You *are* able to run your machine application software on the Application Channel while simultaneously using ClearView on the Diagnostic Channel. We'll discuss how to do that later in this section.

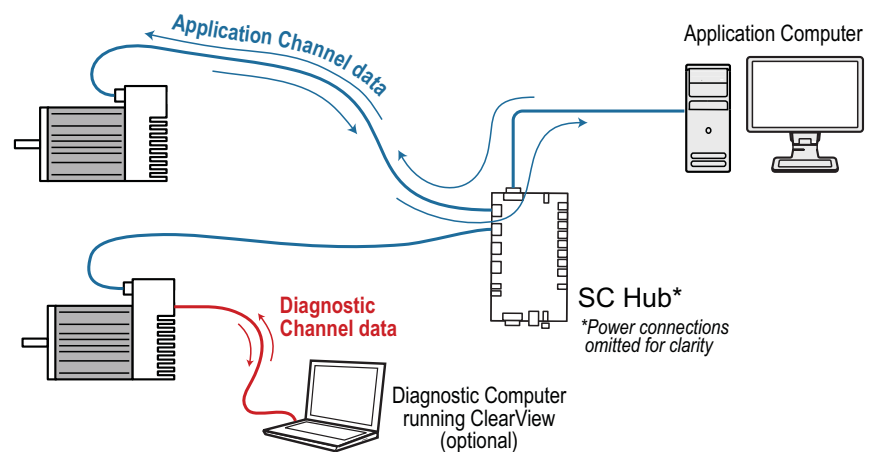

Application and Diagnostic Channels are separate communication paths

CONNECTING TO THE DIAGNOSTIC CHANNEL

This example is based on a system with one SC Hub that has two ClearPath-SC motors connected.

1. Start with a functional ClearPath system that is communicating with ClearView on the Application Channel (ClearView should identify your motors as shown below).

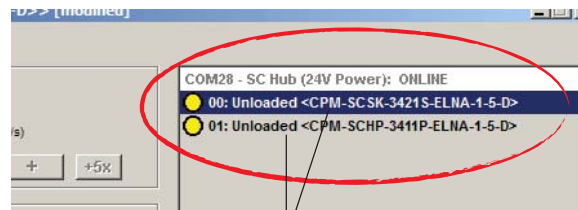

Two ClearPath-SC motors connected to the SC Hub, communicating on the Application Channel using COM 28.

ClearView's Motor List

2. Next, connect a USB cable from the motor's Diagnostic Port to a free USB port on the Application PC, or to a USB port on a separate "Diagnostic PC" if desired.

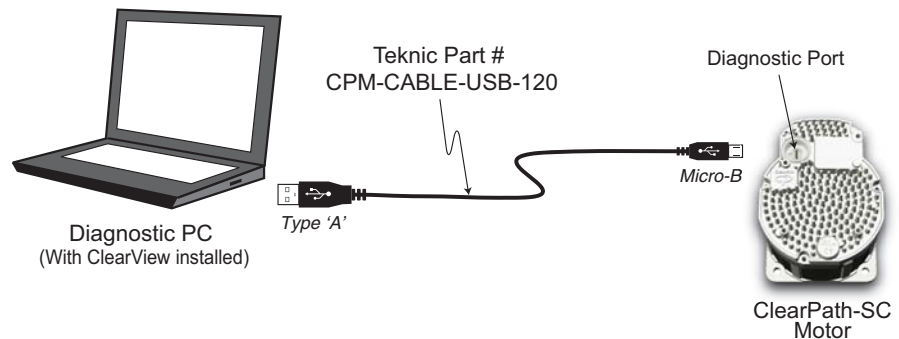

3. In ClearView select File>Preferences. An Application Settings window will pop up. The "First" field should show the Application Channel's COM port setting. It is COM 28 in this example.

Application Channel on COM 28
(your COM port number may vary)

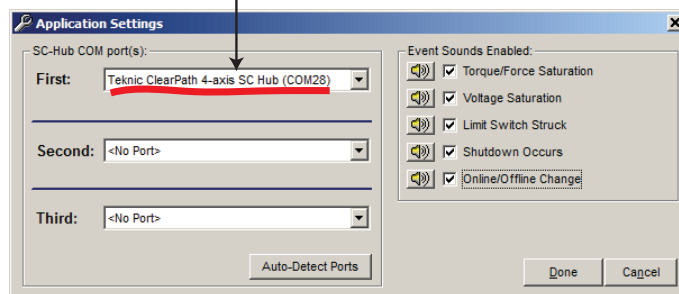

Application Settings window

- Select the "Second" drop down COM port list. Select Teknic ClearPath System (COMx) and click Done.

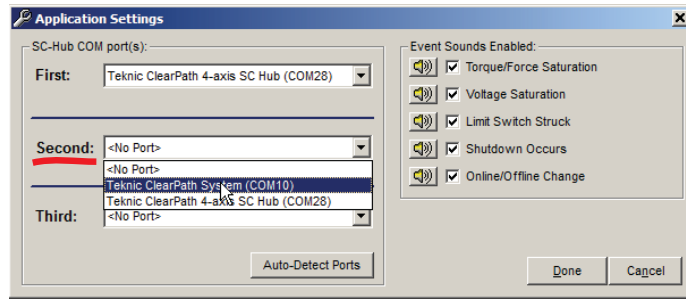

Select the Diagnostic COM port as shown

- The Motor List in ClearView should change to reflect the addition of a motor communicating on the Diagnostic Channel (circled in red below).

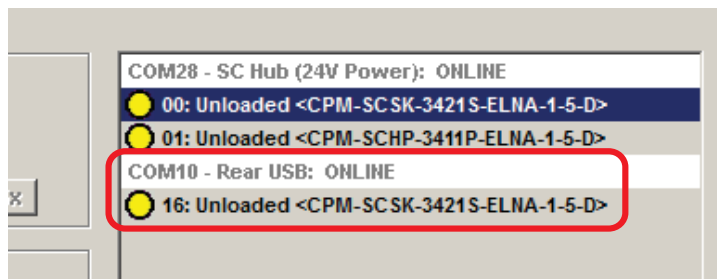

Motor "00" now also shows up as "16" on the Diagnostic Channel (COM 10)

Application Channel vs. Diagnostic Channel

Your ClearPath motor typically communicates with your control PC over the Application Channel. Communication signals on the Application Channel pass through the motor's 8-pin Molex I/O connector, to the SC Hub, and finally to the application computer through a USB or serial port.

In many scenarios, a second communication channel can be helpful. We refer to this as the **Diagnostic Channel**. Communication signals on the Diagnostic Channel pass through the Diagnostic port on the back of your motor. To access the Diagnostic Channel you need a separate USB port and a standard USB cable: Teknic part# CPM-CABLE-USB-120.

CHANGING DIAGNOSTIC CHANNEL ACCESS MODES

1. Select the motor of interest from the Motor List (It should appear under the "Rear USB: ONLINE" heading in the UI).

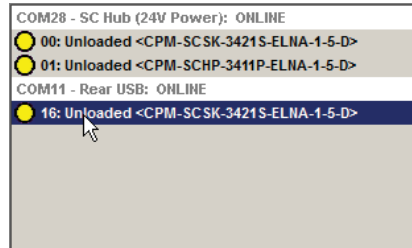

2. Set the access level from the Access menu in ClearView. Users primarily use *Monitor Mode* or *Tune Mode*. Note: Access modes are explained below.

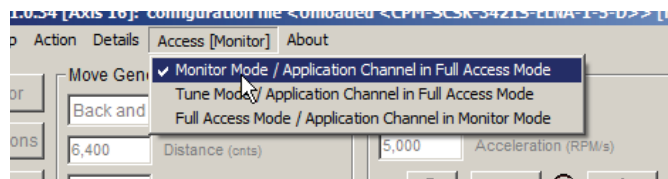

ACCESS MODES EXPLAINED

Monitor Mode

ClearView allows the Diagnostic Channel to access the Soft Scope. ClearView restricts Diagnostic Channel access to most other settings and parameters (restricted items will be grayed out in the UI). The Application Channel has "full access" in this mode.

Tune Mode

ClearView allows the Diagnostic Channel to access the Soft Scope and most of the tuning gains, RAS, and g-Stop settings, tracking error limit, and fine tuning controls. The Application Channel has "full access" in this mode.

Full Access Mode

The Diagnostic Channel has full control of the motor, including access to all normally available settings and parameters. *The Application Channel is forced into "Monitor Mode" in this case.*

TROUBLESHOOTING DIAGNOSTIC CHANNEL CONNECTIONS

If your motors stop communicating with ClearView on one or both channels, or if you get baud rate errors when connecting or reconnecting to the Diagnostic Port, follow these steps:

1. On the SC hub: Remove the 24V power and the USB connector. Wait 10 seconds.
2. Reconnect 24V power and the USB connector.
3. If you still have problems, close and restart ClearView.
4. If the problem persists, Click File>Preferences and manually select the ports from the drop down list. Then click "Done". You may have to restart ClearView as well.

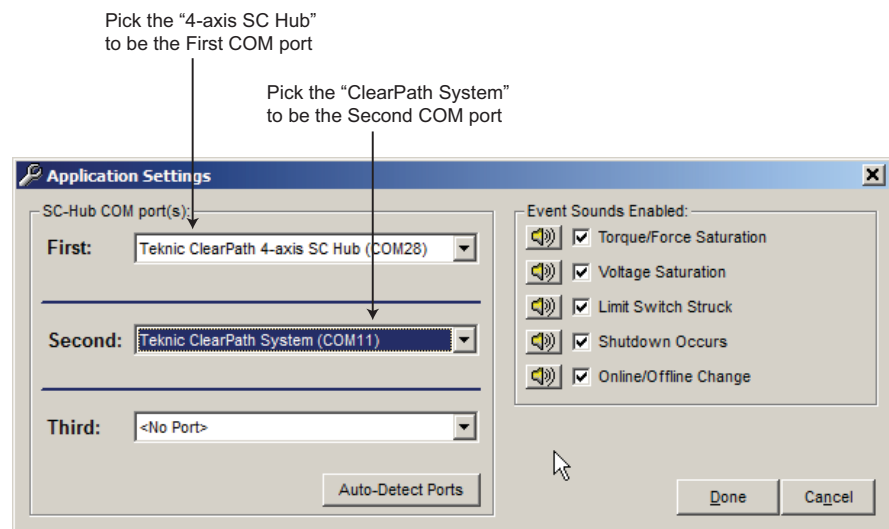

Manually selecting COM ports

SOFTWARE LIBRARY AND SDK OVERVIEW

INTRODUCTION TO THE sFOUNDATION LIBRARY

The ClearPath-SC software foundation, or "sFoundation", is an object-oriented, motion control class library. The sFoundation has versions for C++ and .NET development. This library includes a large number of functions used to interface with, and control your ClearPath-SC integrated servo motor.

The sFoundation also includes a detailed software development kit (SDK) with all the files you'll need to begin coding immediately. In addition, the SDK includes several example projects and a detailed class reference help document.

WHAT'S COVERED IN THIS SECTION

This section provides a brief overview of the topics listed below. Check out the SDK for the complete programming reference, example programs, header and library files and more.

- sFoundation class hierarchy
- Node level functions
- Port level functions
- System level functions
- Software Development Kit (SDK)

Where do I find the sFoundation SDK on my PC?

64-bit systems

[DRIVE]:\Program Files (x86)\Teknic\ClearView\sdk\

32-bit systems

[DRIVE]:\Program Files\Teknic\ClearView\sdk\

sFOUNDATION CLASS HIERARCHY

The sFoundation libraries are organized into a logical hierarchy (see diagram next page) to help software developers understand class relationships and find relevant functions quickly.

The sFoundation comprises three main levels: a Node level, Port level, and System level. A node is just a ClearPath-SC motor. Most of your application software will interface with Node level objects.

You can think of the sFoundation structure as a hierarchy wherein an instance of a System class object "owns" all of the instances of the Port

class objects (objects which interface with USB or serial ports). Port class objects, in turn, “own” all of the instances of the Node class objects.

You would use **Node class** objects to create and execute positional moves, and to query the node's real-time status (Is the motor enabled? Is the move done?).

Port class objects let you manage individual ports and the collection of all nodes on a given port. Port class objects also provide access to Port level features such as group shutdowns.

Finally, a **System class** defines the manager object used to implement system level functions, things like defining and configuring the USB or serial ports in your system, accessing system timestamps, setting up thread safe delays, and providing a safe thread-locking mechanism.

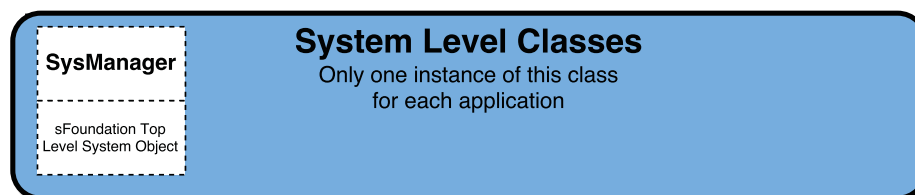
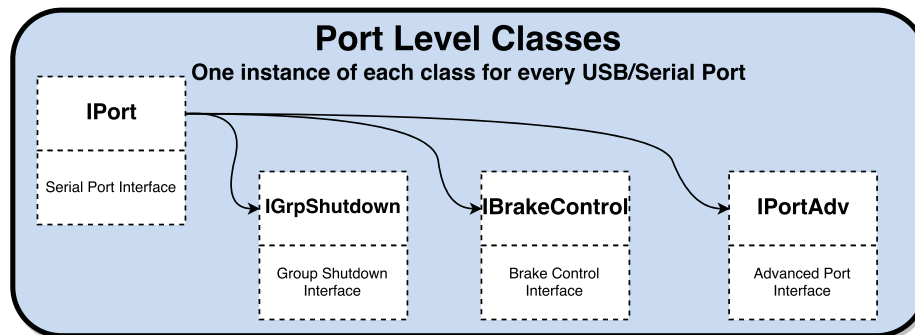
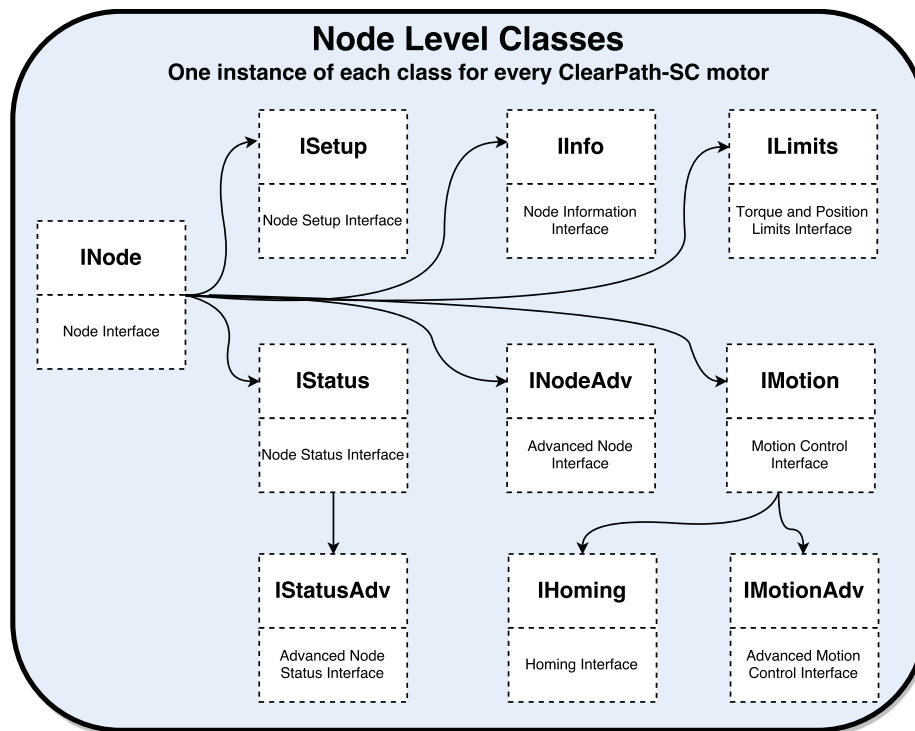

sFoundation Class Hierarchy

INODE (NODE LEVEL CLASSES)

The INode class is used to interface with a node in an application (remember, each node is just a motor). Node level functions and structures are defined separately for each node in a system, so your application will have one instance of each of these structures for each node (motor) in your system.

This class defines a "super" Node whose framework exposes the Node level features available to your application by a series of public attribute references. You can think of each instance of the INode class as "owning" all Node level classes linked to the same node.

FEATURES/ACTIONS

- Issue Enable requests to motors
- Assign units for torque, velocity, and acceleration
- Provides a simple and safe mutex mechanism
- Read Node level inputs
- Provide access to all other Node level features

OTHER NODE LEVEL CLASSES

IMotion

This class is used to set up, initiate, and cancel motion on an individual node. This class contains functions to:

- Start moves (positional, velocity)
- Query the MoveDone status (to determine whether a move has completed)
- Query the Ready status (to determine whether a node is ready to initiate a move)
- Set/get the velocity limit for moves
- Set/get the acceleration limit for moves
- Query instantaneous commanded and measured position, velocity, and torque
- Provide access to homing and advanced motion features

IMotionAdv

This class object allows setup and initiation of advanced motion features (available only in advanced models) including:

- Head/tail moves
- Asymmetric moves
- Triggered moves
- A after start/ B before end events

IInfo

This class object provides access to node information including:

- Serial number
- Node type
- Firmware version
- User defined node specific information

IStatus

This class object accesses and manages the node status information in status/alert registers. These registers include information such as:

- In Range status
- Input A/B
- Ready status
- Shutdown state
- In Motion status

IStatusAdv

This class accesses and manages the advanced node status information. It provides access to position capture registers (available on advanced models only).

IHoming

This class object gives you hooks into Teknic's homing engine so you can initiate, and check the status of a homing move.

Note: The IHoming class does not configure homing parameters (homing direction, homing speed, etc.). Homing parameters are set quickly and easily right in the ClearView software UI.

ILimits

This class accesses the global torque limit and positional tracking error limit.

ISetup

This class object accesses and manages node setup features such as loading and saving motor configuration files to and from nodes.

IPORT (PORT LEVEL CLASSES)

The IPort class is used to interface with a port on your computer which, in turn, interfaces to a series of nodes. This class defines a "super" Port whose framework exposes the Port Level features available for your application by a series of public attribute references. You can think of the IPort class as "owning" all other port level classes. Port Level functions and structures are defined separately for each port in a system.

FEATURES/ACTIONS

- Request node counts
- Restart nodes on a port network
- Determine the port network's operational state

- Create command trace files logging the history of the last 4096 commands sent through this port
- Issue high priority stop commands to every node on the port
- Provides access to all other Port level classes

OTHER PORT LEVEL CLASSES

IGrpShutdown

Supports control of the group shutdown feature (which allows an electrical connection on the SC Hub board or a change in a node's status to initiate a Group Shutdown).

IBrakeControl

Supports control of the brake control outputs on the SC Hub board.

Note: If multiple SC Hub boards are chained together on a single port, only the first SC Hub board's brake outputs will be controllable.

IPortAdv

Supports control of advanced features such as **Group Triggering** and **attention handling** (available on advanced models only).

SYSMANAGER (SYSTEM LEVEL CLASS)

Sometimes called the "root object" for the sFoundation, this is the main application class used to interface with Teknic nodes attached to serial and/or USB ports. Its purpose is to coordinate actions among the various ports, and, to some extent, within the node environment.

COMMON FEATURES

- Port specification function
- Open and close ports, detect any attached nodes
- Access network maintenance features, such as restarting nodes, or re-enumerating the nodes on the port
- Delay function (to suspend thread execution)
- Includes a thread-locking class

SOFTWARE DEVELOPMENT KIT (SDK)

The sFoundation class libraries come with a detailed software development kit (SDK) to help make your software development as straightforward and efficient as possible.

The SDK includes all of the files a developer will need to begin coding, including:

- Header files
- Library .dll
- Class reference help file
- Fully functional example projects, available in both C++ and C#

Tip: Before beginning software development, you may want to copy the complete SDK folder into a different working directory on your computer and leave an unmodified copy of the SDK in the default installation location.

WHERE IS THE SDK LOCATED?

The SDK files are copied to your local machine as part of the ClearView installation process, and can be found in one the following directories:

[YOUR_DRIVE]:\Program Files (x86)\Teknic\ClearView\sdk\
or

[YOUR_DRIVE]:\Program Files\Teknic\ClearView\sdk\
or

APPENDIX A: MOTOR LED BLINK CODES

Note: The motor LED periodically blinks off to indicate active communication between the motor and the host PC. This communication blinking takes place concurrently with the LED behavior defined in the table below. See examples below for clarification.

Example 1: A motor that is disabled will exhibit a solid green LED, but the LED will periodically blink off and back on during communication with the host PC.

Example 2: An enabled motor will exhibit a rapid green flicker, but the flicker pattern will be interrupted periodically during communication with the host PC. (It will look like a rapid flicker mixed with a slow blink.)

LED Behavior	CPSC State	Description
Green Flicker	Enabled	Operation normal. CAUTION: Motor windings are energized. Motor can move at any time.
Solid Green	Disabled	Operation normal. Motor windings are de-energized.
Yellow Blink	Shutdown	Query drive through application code for exception information, or connect to motor via Diagnostic Port with secondary laptop (running ClearView).
Red Blink	Fatal error	Motor hardware failure possible. Request RMA if condition persists.
Off	No or low DC bus power	Apply DC bus power to motor. Verify power supply meets system power requirements.

MOUNTING DIMENSIONS: CLEARPATH-SC NEMA 23

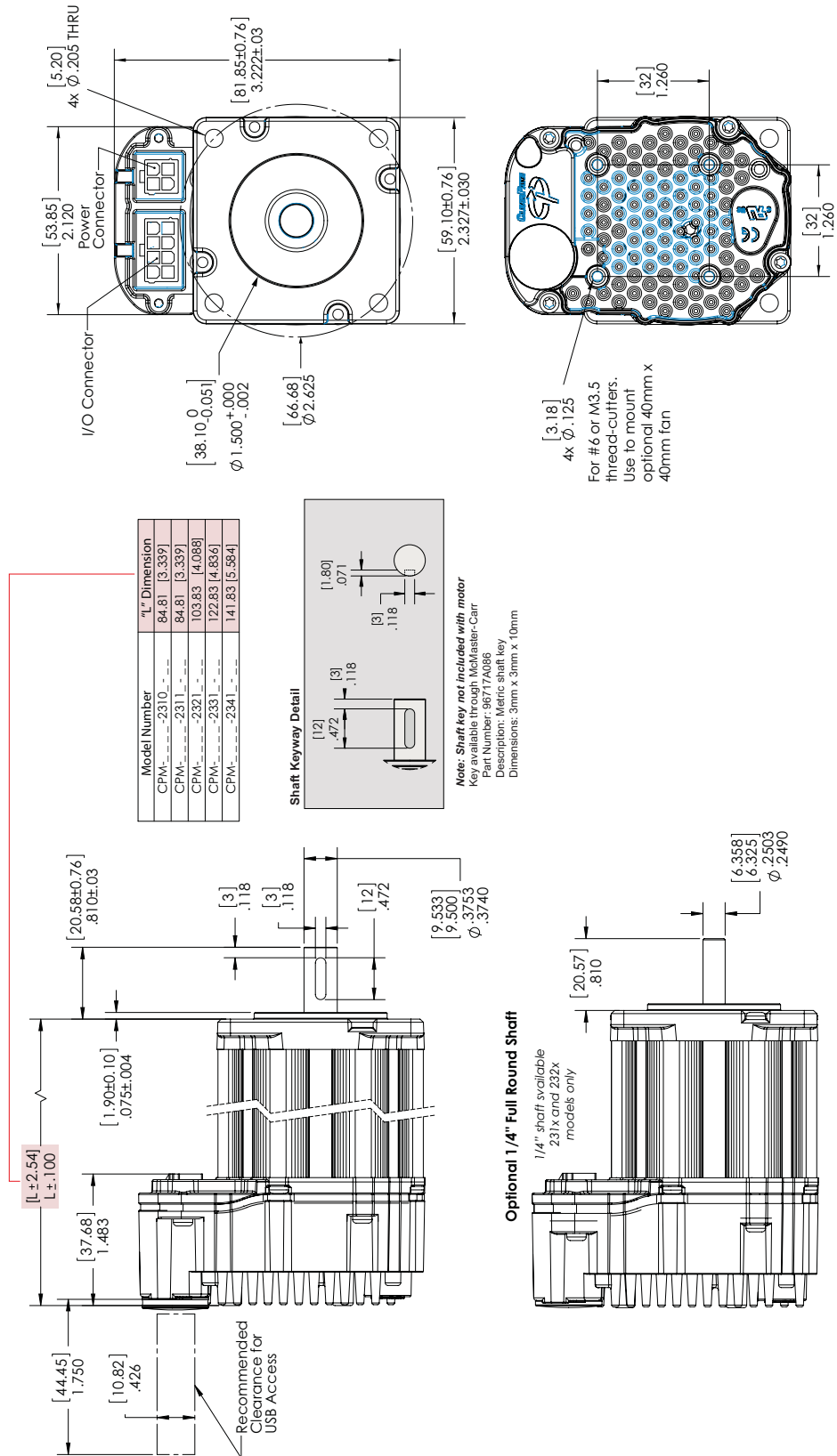

MOTOR MOUNTING, THERMAL CONSIDERATIONS

- Do not mount ClearPath-SC over a heat source such as a power supply, spindle drive, etc.
- Do not mount ClearPath-SC in an unventilated enclosure.
- Do allow for at least 1” of space around each ClearPath-SC.
- ClearPath-SC can be fitted with an external accessory fan if desired.
- ClearPath-SC will perform a protective shutdown when its internal temperature sensor threshold is exceeded.

Tip: Teknic recommends mounting the motor such that the USB port and status LED are visible and accessible when the motor is mounted to the machine.

MOUNTING DIMENSIONS: SC HUB

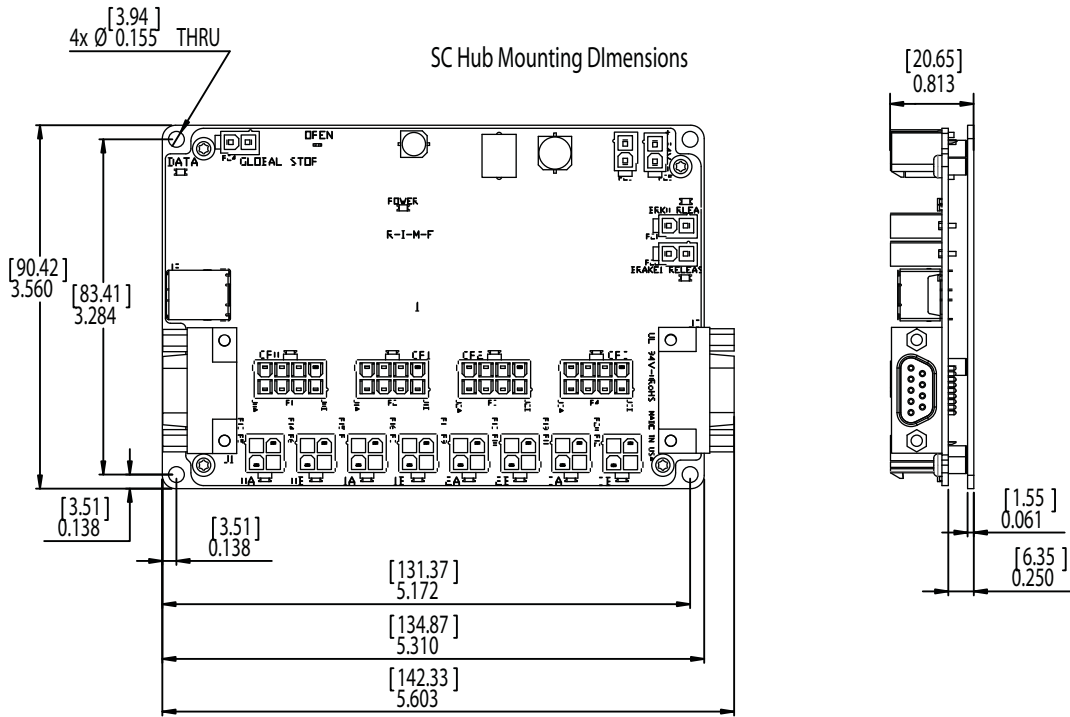

Mounting pattern for chaining multiple SC Hubs end-to-end using onboard DB-9 connectors.

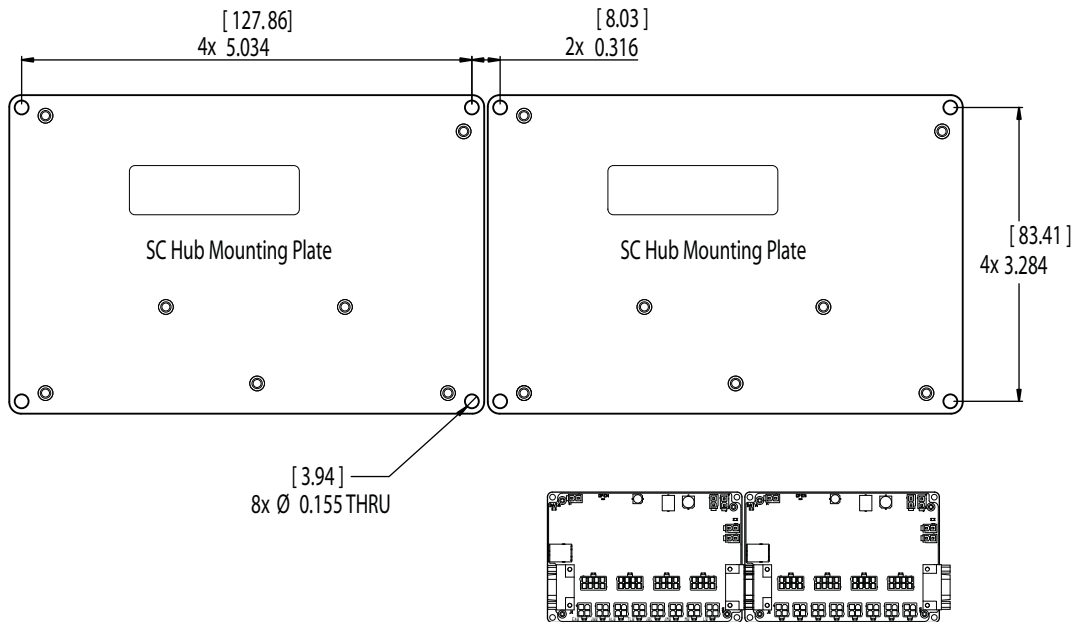

SC Hub Mounting Dimensions

MOUNTING DIMENSIONS: POWER HUB

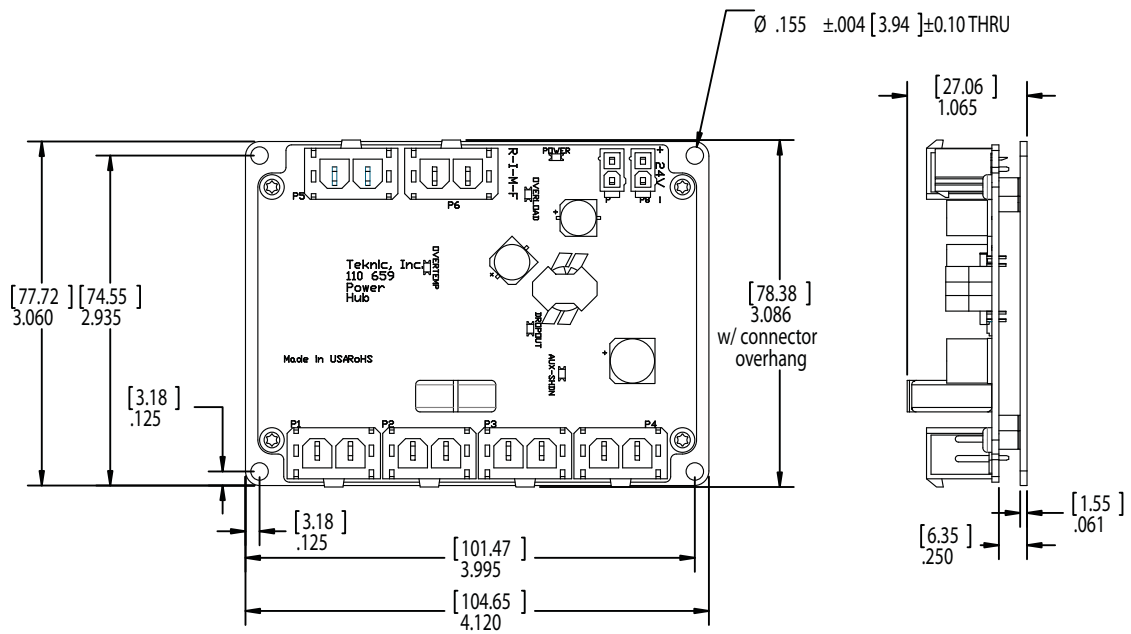

Power Hub Mounting Dimensions

CONNECTING CLEARPATH-SC TO A MECHANICAL SYSTEM

ClearPath-SC motor must be connected to a mechanical system to do any useful work, but it's not always clear just how to connect the motor to the rest of the machine.

Problems arise when a connecting element (such as a coupling) slips, exhibits excessive backlash, or can not accommodate typical shaft-to-shaft misalignments. Ultimately, the choice of shaft interface or coupling depends on the application, whether a precision positioning stage or a low speed conveyor.

The shaft interface (coupling, pulley, pinion, etc.) must be securely clamped to the shaft with minimum backlash (ideally none). This primary mechanical interface is critical in achieving and maintaining the best possible performance from a servo motion system.

MOTOR CONNECTION: GENERAL TIPS AND GUIDELINES

- **Align with care.** When connecting two shafts—such as a motor shaft to a screw shaft—the rotating centers must be carefully aligned in both the angular and offset sense (including offsets/adjustments for thermal growth) to achieve the best possible motion quality and longest motor/bearing life.

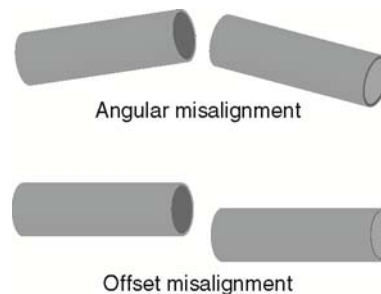

Some couplings are more forgiving of misalignment than others, but in general, misalignment will cause undesired vibration/noise, shortened bearing life, and even broken motor shafts.

- **Use lightweight components.** Aluminum couplings, pinions, and pulleys add significantly less inertia to the motion system than steel parts of the same size. In most applications, lower inertia is preferable because it allows the motor (and attached mechanics) to accelerate harder and move and settle faster.
- **Avoid using set screws.** Coupling devices with set screws are prone to failure and often become the weak link when joining a motor to a load. Set screws deform the metal around the screw's point of contact, often resulting in a raised burr on the shaft that can make it hard to remove and replace the coupling element. Set screws also tend to slip and score the shaft.
- **Tip:** Couplings, pulleys and pinions with circumferential clamping mechanisms tend not to damage motor shaft, hold better, and are easier to replace than those that use set screws.

- **Clamp close to the motor.** For maximum performance, secure pulleys and pinions as close to the motor face as practical. This effectively reduces the lever arm (and associated bearing load) for applications with a side load.
- **Don't over tighten belts.** Always read the belt manufacturer's guidelines for proper belt tension, but never exceed the ClearPath-SC specification for maximum side load. Overly tight belts put undue stress on the motor shaft and bearing systems that can result in premature bearing and shaft failure.
- **Avoid using shaft keys when possible.** Although ClearPath-SC includes a keyway feature on the shaft, Teknic does not generally recommend the use of keys. Keys tend to cause run-out and backlash errors, particularly in reciprocating, precision positioning motion applications.
- **Note:** Keys *should be* considered for use in applications where coupling slip could result in a dangerous or hazardous condition. Also, key use may be appropriate for unidirectional applications (where the motor always spins in the same direction) as these applications are less prone to key-related lash problems.
- **Avoid direct loads.** In general, ClearPath-SC motors are not designed for connection to direct loads (e.g. direct connection to a grinding wheel). However, direct connection may make sense if the load is of low-mass and balanced, as with small mirrors for laser applications.

NOTES ON COUPLING SELECTION.

A complete coverage of the topic *Coupling Selection for Servo Applications* is beyond the scope of this document, but many articles and resources can be found on the web for those interested in learning more. Because there are so many different coupling styles and applications, selecting the “right” coupling for a particular application can be challenging.

General Guidelines for Coupling Selection

Teknic has a few guiding principles when it comes to coupling selection for servo applications. Keep in mind that these are rules of thumb and may not apply to every application. In general:

- **Don’t** undersize the coupling. Understand how much torque your application requires and stay within the coupling manufacturers specifications. Always leave reasonable engineering margin.
- **Don’t** use set screw type couplings. They damage the motor shaft and tend to be less reliable over time than clamp style couplings.
- **Do** use clamp style couplings. These clamp around the circumference of the shaft at one or two points without deforming the shaft surface.
- **Don’t** use rigid couplings—they are notoriously intolerant of misalignments.
- **Don’t** use beam style (helical) couplings if vibration damping or torsional stiffness is critical to your application. Beam couplings tend to resonate/whine at higher speeds.
- **Don’t** use any coupling that requires you to drill into, deform, or “pin” the motor shaft.

Coupling Recommendation

Teknic often recommends **zero-backlash curved jaw couplings** (commonly referred to as “spider couplings”) as a good choice for many servo applications. These couplings are moderately priced and widely available from well established manufacturers such as Ruland.



Curved Jaw (Spider) Coupling



Bellows Coupling

Couplings for servo applications

Note: Curved jaw couplings (also known as spider couplings) are a good choice for many applications, but cannot tolerate a great deal of misalignment or axial motion. Also, never exceed the manufacturer’s rating for “maximum torque with zero backlash” when using jaw couplings.

Bellows couplings are also excellent for high precision positioning applications. Bellows couplings allow for more misalignment than jaw couplings but are generally more expensive.

Both curved jaw and bellows coupling offer excellent positioning accuracy, high speed performance, and vibration damping when installed and operated within the manufacturer's specifications and guidelines.

Coupling Information on the Web

Ruland's website has a good collection of technical information on coupling types and coupling selection for servo systems. See links below.

<https://www.ruland.com/technical-resources/technical-articles>

<https://www.ruland.com/technical-resources/technical-articles/5-reasons-to-consider-using-jaw-couplings>

INSTALLING PULLEYS AND PINIONS

PULLEY AND PINION MOUNTING

- Always follow the manufacturers mounting guidelines.
- Mount pulleys and pinions as close to the motor face as possible while still following the manufacturer's installation guidelines.
- Never drill through, "pin", or deform the motor shaft when mounting a pulley or pinion.

Application Tip: To prevent loosening/slip, some users bond their pulleys and pinions to the motor shaft with a high strength adhesive such as Loctite #638. While this is very effective in preventing pulley slip, it can be difficult to undo once the adhesive has cured.

ABOUT END-OF-TRAVEL STOPS.

End-of-travel stops are typically installed to prevent the moving element of a linear axis from flying off the machine in the event of a use or control error. There are a few common types of end stop to consider, but the final choice depends on the application objectives and requirements.

HARD BLOCKS

This is usually a solid block of steel, aluminum, or hard plastic secured at one or both ends of travel and positioned in such a way as to make even, repeatable contact with a hard surface on the moving element. Hard blocks are very effective at arresting motion, but can result in mechanical damage when struck at high speeds.

In several modes, ClearPath-SC must home to a hard stop to establish a home reference position before functional positioning can begin.

ELASTOMERIC (RUBBER) STOPS

High durometer rubber stops (hard rubber) can also be used with applications that use HardStop Homing. This type of end stop offers a higher level of shock absorption and axis protection than hard blocks. Spongy, low durometer rubber stops are not recommended in most cases. They offer little benefit over a hard end stop during an axis crash.

PNEUMATIC (DASHPOTS)

Pneumatic hard stops (dashpots) offer excellent shock absorption performance but are considerably more expensive than hard blocks. Examples of specialized dashpots include the hydraulic cylinder in an automobile shock absorber as well as many automatic door closers.

END STOPS AND HARD STOP HOMING

End stops from medium durometer rubber to steel can be used successfully with Hard Stop Homing. When selecting end stops for a Hard Stop Homing application consider the following:

- Axes with low friction that are easily back driven can tolerate “softer” rubber end stops and still achieve good homing performance.
- Higher friction applications and those that cannot be back driven will generally require harder end stop material to achieve best Hard Stop Homing performance.
- Be prepared to test and experiment with different end block materials to ensure proper homing operation with your mechanical system.

FAN MOUNTING AND COOLING.

All ClearPath-SC motors have unthreaded mounting bosses on the rear casting to accommodate standard DC computer fans (60mm for NEMA 34 motors, or 40mm for NEMA23 size motors). See the diagram below for mounting dimensions, hardware and fan sizes. Teknic does not sell accessory fans, but they are readily available through electronics suppliers including Digikey and Mouser.

Note: As a self-protective measure, ClearPath-SC motors will shut down when the rear enclosure reaches 80° C (176° F). After a thermal shutdown occurs, the motor must cool sufficiently before it will operate again.

Reminder: If you install a fan, you'll have to power it. Most computer fans require 12VDC or 24VDC.

ClearPath NEMA 34

Designed for 60mm fans rated at 11 CFM or greater

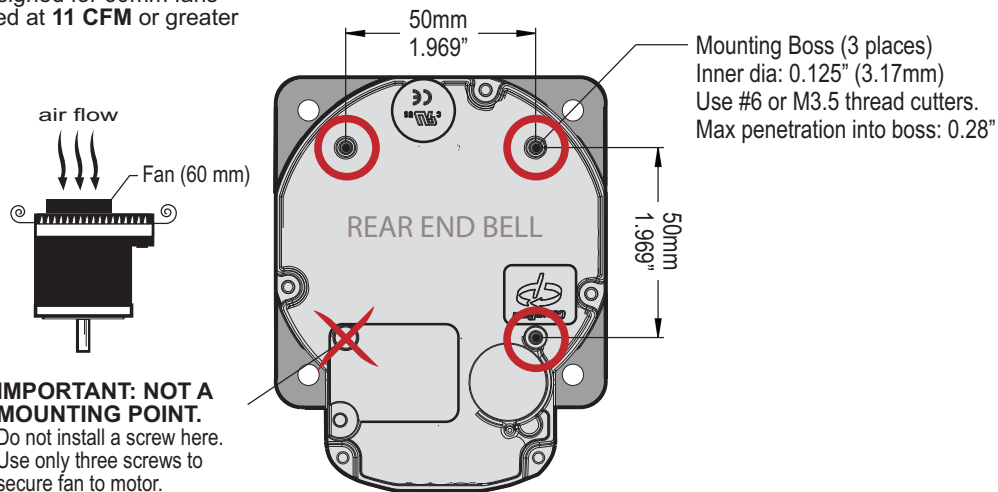

ClearPath NEMA 23

Designed for 40mm fans rated at 5 CFM or greater

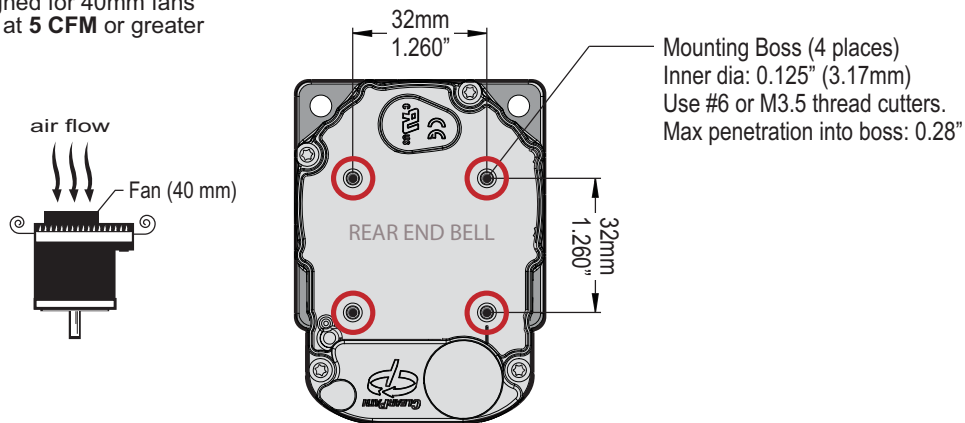

APPENDIX C: MATING CONNECTORS AND CABLE PINOUTS

MATING CONNECTORS

This section contains a list of Molex mating connectors, terminals, and hand tools that can be used to build cables for the ClearPath-SC system. It is the user's responsibility to review and verify all mating part specifications and application instructions with Molex Inc. before building cables for use with ClearPath-SC components.

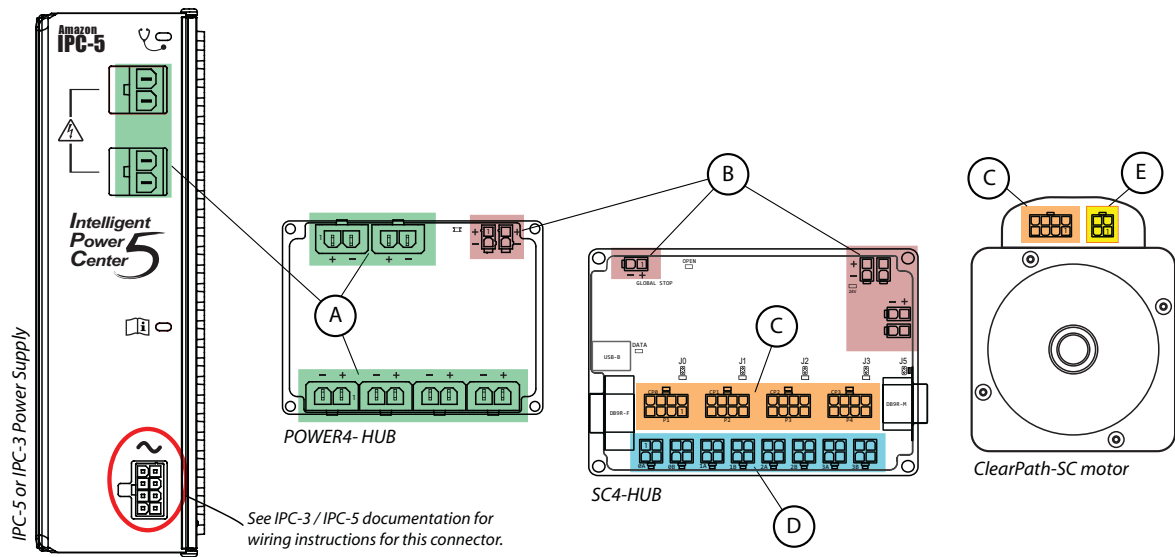

All parts listed below are manufactured by Molex Inc. Visit www.molex.com for complete specifications and application information.

Ref.	Description	Mating Connector PN	Terminal PN	Terminal Desc.	Crimp Tool	Extraction Tool	Recommended Wire Gauge ²
A	Molex Sabre, Receptacle, 2 circuits	44441-1002 (black, UL 94V-2) 44441-2002 (black, UL 94V-0)	43375-0001	Female crimp terminal, tin plate, 14-16 AWG	63811-7200 (14-16 AWG)	63813-2700	16 AWG
B	Molex MiniFit-Jr, Receptacle, 2 circuits	39-01-2020 (natural, UL 94V-2) 39-01-3025 (black, UL 94V-2) 39-01-3028 (natural, UL 94V-0) 39-03-9022 (black, UL 94V-0)	39-00-0059 (reel) 39-00-0060 (loose)	Female crimp terminal, tin plate, 18-24 AWG	63819-0901 (18-24 AWG)	11-03-0044	20 AWG
C	Molex MiniFit-Jr, Receptacle, 8 circuits	39-01-2080 (natural, UL 94V-2) 39-01-3085 (black, UL 94V-2) 39-01-2085 (natural, UL 94V-0) 39-03-9082 (black, UL 94V-0)	39-00-0046 (reel) 39-00-0047 (loose)	Female crimp terminal, tin plate, 22-28 AWG	63819-1000 (22-28 AWG)	11-03-0044	22 AWG
D ¹	Molex MiniFit-Jr, Receptacle, 4 circuits	39-01-2040 (natural, UL 94V-2) 39-01-3045 (black, UL 94V-2) 39-01-2045 (natural, UL 94V-0) 39-03-9042 (black, UL 94V-0)	39-00-0046 (reel) 39-00-0047 (loose)	Female crimp terminal, tin plate, 22-28 AWG	63819-1000 (22-28 AWG)	11-03-0044	22 AWG
E ¹	Molex MiniFit-Jr, Receptacle, 4 circuits ¹	39-01-2040 (natural, UL 94V-2) 39-01-3045 (black, UL 94V-2) 39-01-2045 (natural, UL 94V-0) 39-03-9042 (black, UL 94V-0)	39-00-0077 (reel) 39-00-0078 (loose)	Female crimp terminal, tin plate, 16 AWG	200218-2200 (16 AWG)	11-03-0044	16 AWG

¹Important: For D and E, observe differences in specified terminal, wire gauge, and crimp tool. While the same connector housing is used for D and E, the associated circuits carry significantly different max. voltage and current loads.

²AWG values listed are the actual wire gauges used in Teknic-manufactured cables.

CABLE PINOUTS

CONTROL CABLE: CPM-CABLE-CTRL-MU120

Cable description: ClearPath I/O connector cable, ~122 inches end-to-end. Overmolded Molex MiniFit Jr. 8-position connector to standard MiniFit Jr. 8-position connector (no overmolding on one end for easy access to wires).

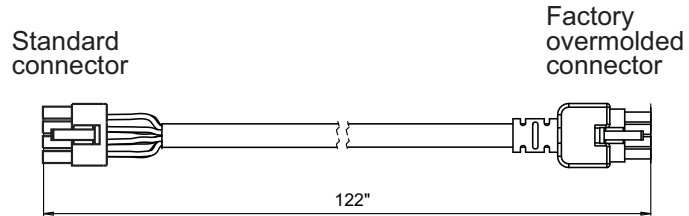

Pin Assignments		
Pin	Color	Name
1	GRN	SC Data - (from motor)
2	BLK	Input B +
3	WHT	Input A +
4	BLU	User Data + (to motor)
5	RED	SC Data + (from motor)
6	YEL	Input B -
7	BRN	Input A -
8	ORN	User Data - (to motor)

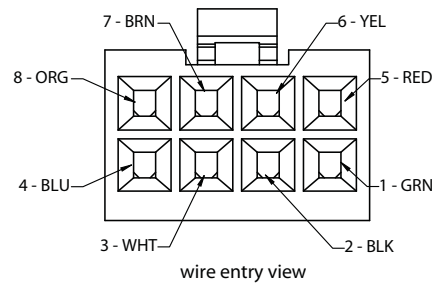

CONTROL CABLE: CPM-CABLE-CTRL-MM660

Cable description: ClearPath I/O connector cable (double-ended), ~662" end-to-end. Overmolded Molex MiniFit Jr. 8-position connector to same. Use "as is" or cut in half to make two cables with flying leads.

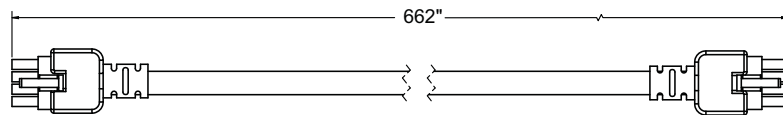

Pin Assignments		
Pin	Color	Name
1	GRN	SC Data - (from motor)
2	BLK	Input B +
3	WHT	Input A +
4	BLU	User Data + (to motor)
5	RED	SC Data + (from motor)
6	YEL	Input B -
7	BRN	Input A -
8	ORN	User Data - (to motor)

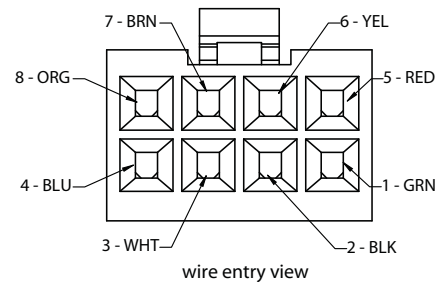

CONTROL CABLE: MOLEX BRAND (2 METERS AND SHORTER)

Molex stocks a few shorter, ClearPath-compatible control cables through their website (see URLs below).

Cable description: These cables are overmolded Molex MiniFit Jr. 8-position connector to same, with 18AWG wires. Available lengths include 0.5 meter, 1 meter, and 2 meters.

Note: The wire colors for the Molex brand cables are not identical to the wire colors used in the Teknic brand cables (listed on the previous page). This will not affect cable operation.

Length	Molex PN	Link
0.5 m	2451350805	https://www.molex.com/molex/products/part-detail/cable_assemblies/2451350805
1.0 m	2451350810	https://www.molex.com/molex/products/part-detail/cable_assemblies/2451350810
2.0 m	2451350820	https://www.molex.com/molex/products/part-detail/cable_assemblies/2451350820

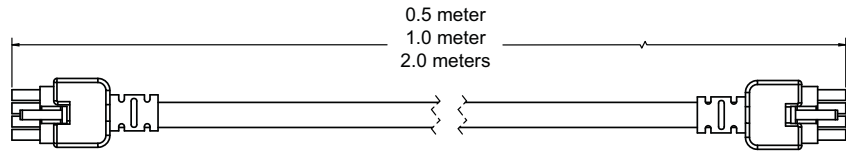

Pin Assignments		
Pin	Color	Name
1	BLK	SC Data - (from motor)
2	RED	Input B +
3	WHT	Input A +
4	GRN	User Data + (to motor)
5	ORN	SC Data + (from motor)
6	BLU	Input B -
7	YEL	Input A -
8	GRY	User Data - (to motor)

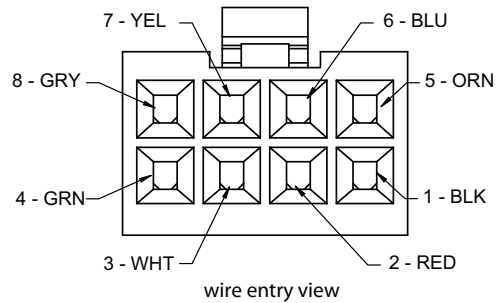

POWER CABLE: CPM-CABLE-PWR-MM660

Cable description: ClearPath power cable (double-ended). MiniFit Jr. 4-position connector to same. Designed to be cut in half (or as needed) to make up to two custom-length power cables with flying leads.

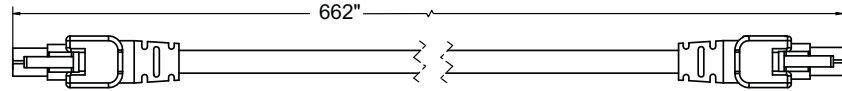

Pin Assignments		
Pin	Color	Name
2	BLK	GND
3	RED	V+

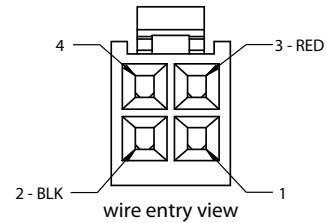

POWER CABLE: CPM-CABLE-PWR-MS120

Cable description: ClearPath power cable. This cable connects the DC output of a Teknic IPC-3 or IPC-5 power supply to the ClearPath power input connector. It features a Sabre 2-position connector to Molex MiniFit Jr. 4-position connector.

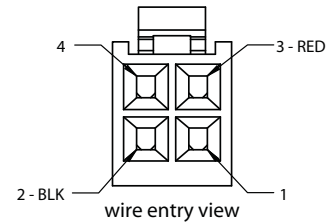
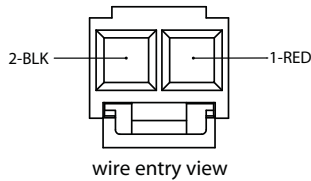
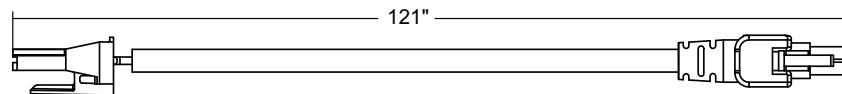

Pin Assignments		
Pin	Color	Name
1	RED	V+
2	BLK	GND

Pin Assignments		
Pin	Color	Name
2	BLK	GND
3	RED	V+

APPENDIX D: SPECIFICATIONS

CLEARPATH-SC MOTOR: COMMON SPECIFICATIONS

Electrical Power Requirements:

Supply Voltage, Typical:	24VDC to 75VDC
Supply Voltage, Absolute Min:	21.5VDC (as measured at input terminals)
Supply Voltage, Absolute Max:	90VDC (as measured at input terminals)
Continuous Bus Current, Typical:	1A to 4A (application dependent)
Continuous Bus Current, Maximum:	10A
Idle Power usage from Bus:	4W (enabled, no torque used by axis or load) 3W (disabled)

Electrical I/O:

Logic Input Voltage Range:	4.0VDC to 28VDC
Input Current @ 5V:	7.5mA (min.)
Input Current @ 28V:	12.0mA (min.)

Motor Bearing, NEMA34:

Maximum Radial Load, NEMA34:	220N (50-lbs), applied 25mm (1.0in) from front bearing
Maximum Thrust Load, NEMA34:	44N (10-lbs)
Bearing Life, NEMA34:	2.4 x10 ⁹ to 5.3 x10 ⁹ revs (typ., load dependent.)

Motor Bearing, NEMA23:

Maximum Radial Load, NEMA23:	110N (25 lbs), applied 25mm (1.0in) from front bearing
Maximum Thrust Load, NEMA23:	22N (5 lbs)
Bearing Life, NEMA23:	3.2 x10 ⁹ to 5.0 x10 ⁹ revs (typ., load dependent.)

Environmental:

Shock (peak, maximum):	10G (applied no more than twice)
Vibration (RMS, 2 Hz-200 Hz):	1.0G or 0.5mm, whichever is less
Maximum External Shaft Deceleration:	250,000 rad/s ²
Ambient Temperature:	-40°C to +70°C*
Maximum Body Temp.:	100°C
Maximum Rear Cover Temp.:	70°C
Humidity:	0% to 90%, Non-Condensing
Recommended Optional Fan, NEMA23:	40mm square, 45.25 mm bolt center, >= 5 CFM
Recommended Optional Fan, NEMA34:	60mm square, 70.71 mm bolt center, >= 11 CFM

Environmental Sealing:

Front Face, with shaft seal option:	IP65
Front Face, without shaft seal option:	IP53
Body/rear, with dielectric grease in connectors:	IP55
Body/rear, no sealing provisions:	IP53

Compliance:

Regulatory Certifications:	UL recognized, CE, RoHS
Electrical Safety:	UL508C, EN 61010-1
EMI:	EN 61326-1

Country of Origin:

USA

Warranty:

3 years

*The RMS torque limit on certain motors is derated for operation in ambient temperatures above +40°C. Contact Teknic for derating assistance.

POWER4-HUB SPECIFICATIONS

24V power input (aux. power supply)

Specified voltage range:	20VDC to 30VDC
Absolute maximum input voltage:	40 VDC
Current draw:	400mA Max.
Connectors:	2-pin Molex MiniFit Jr. (P7, P8)
A labeled green LED on the board will light when 24V power is connected.	

75V power input (motor bus power)

Specified voltage range:	20VDC to 90VDC
Maximum input voltage:	100VDC
Continuous current draw:	20A
10-second current draw:	60A
Connectors:	2-pin Molex Sabre (P5, P6)

Power outputs to ClearPath motors

Max motors:	4
Connectors:	2-pin Molex Sabre (P1, P2, P3, P4)

Short-circuit protection

Actively protects connected power supplies from short-circuit/overload damage. No reset or fuse replacement is necessary after a short-circuit or overload incident.
A labeled red LED on the board will light when short-circuit protection is activated.

Operating Temperature

40C Max.

Under voltage shutdown protection

Upon loss of motor bus power, the Power Hub will automatically switch over to low-voltage aux. power to keep ClearPath communications and position tracking online.
A labeled red LED on the board will light in a motor bus under voltage condition.

Auxiliary overload protection

Aux. overload threshold	1.0A
-------------------------	------

If an aux. overload event occurs while aux. power is active, the aux power supply will shut down until the 24V supply is power cycled.
A labeled red LED on the board will light (and remain lit) when an aux. overload condition occurs.

Dimensions:

L x W x H (w/o plate)	3.92" x 3.09" x 0.95"
-----------------------	-----------------------

Country of Origin:

USA

Warranty:

1 year

SC4-HUB SPECIFICATIONS

USB

USB Standard	USB 2.0 w/hub, USB 1.1 direct
Power Draw	If 24V is present, 0.4mA max If 24V is not present, 150mA max.
Connector:	USB-B

RS-232 to PC

Compatible baud rates:	Up to 230 kBaud
Connector:	DB-9 female, use DB-9 straight-through cable (male to female) to connect to PC

RS-232 Extension

Compatibility:	Intended for direct connection to another SC Hub board only.
Connector:	DB-9 male (can be plugged directly into J1 of another SC Hub, or through another straight-through DB-9 cable)

Global Stop Input

Input Type:	Isolated loop
Specified voltage range:	0-24VDC
Current draw:	2mA@4.5V, 12mA@24V
Min. guaranteed on voltage:	3.0VDC
Max. guaranteed off voltage:	2.0VDC
Max. input voltage:	26VDC
Connector:	2-pin MiniFit Jr.

Brake Outputs

Output type:	Powered open collector
Output voltage:	24VDC
Rated current:	500mA per channel, max.
Short circuit protected with built-in inductive clamp	
Connectors:	2-pin MiniFit Jr. (x2)

Power input

Specified voltage range:	20VDC to 30VDC
Max. input voltage	40VDC
Current draw:	300mA (+ up to 500mA per brake)
Connectors:	2-pin MiniFit Jr. (x2)

ClearPath Interface

Compatibility:	Intended for direct connection to a ClearPath-SC motor only
Connectors:	8-pin MiniFit Jr. (x4)

ClearPath Inputs A and B passthrough

Direct passthrough of ClearPath inputs A and B with 24V courtesy power for sensors	
Connectors:	4-pin MiniFit Jr. (x8)

Dimensions:

L x W x H (w/o plate)	5.60" x 3.50" x 0.65"
L x W x H (with plate)	5.60" x 3.56" x 0.82"

Operating Temperature: 40C Max.

Country of Origin: USA

Warranty: 1 year

APPENDIX E: GROUNDING AND SHIELDING

PROTECTIVE EARTH (PE) CONNECTION

Compliance Note: ClearPath-SC must be properly connected to the machine's Protective Earth terminal to meet EMC emissions specification EN-61000-6-4, and EMC immunity specification EN-61000-6-2, as well as EMC electrical safety specification EN-61010 (for CE/UL compliance).

Connect ClearPath-SC to your machine's Protective Earth terminal (PE) using one of the following methods.

- **If the motor mounting plate is bonded to machine PE (typical)**, most of the work is already done. Simply secure ClearPath-SC to the mounting plate with conductive fasteners (don't use anodized or coated hardware). Ensure direct, bare metal-to-metal contact between the ClearPath-SC motor face and mounting surface.
- **If the motor mounting plate is *not* bonded to machine PE** it's still easy to make a good PE connection. Just install a grounding wire from ClearPath-SC's Auxiliary PE Connection Point (located on the motor's rear casting) to a point on the machine that is bonded to machine PE. **Use #6-32, thread forming screw, 5/16" length** (McMaster-Carr PN 93878A145). Use grounding wire with same AWG number (or heavier) as the ClearPath DC power input wiring.

Note: In scenarios where ClearPath-SC is *not* connected to a PE (Protective Earth) return path—such as during bench testing or maintenance—temporary grounding measures may be necessary to comply with safety requirements.

GROUNDING AND SHIELDING

- Always maintain separation between isolated control ground and power ground.
- Shielded cable is not required for ClearPath-SC control cables.
- If you choose to use shielded control cable, connect the cable's isolated ground at one point at the controller only. Do not hook isolated control ground to the machine frame or chassis at any other location.
- Do not ground ClearPath-SC I/O circuits to the machine frame or chassis.

Note: All ClearPath-SC I/O signals are electrically isolated from ClearPath-SC's DC power input and motor output circuits, as well as from the motor case. This design feature helps to ensure that control signals aren't compromised by induced currents from the motor, power supply, or internal PWM.

POWER RETURNS

- Never use the machine frame or chassis as a power return. Use discrete cable or wires for all power wiring.
- Use only recommended wire gauge (16-18AWG typical) for all ClearPath-SC power wiring. When in doubt, use heavier wire.

APPENDIX F: CIRCUIT SCHEMATICS

All schematics in this section are functionally accurate. Certain advanced circuit elements have been omitted for clarity.

POWER4-HUB SCHEMATIC (SIMPLIFIED)

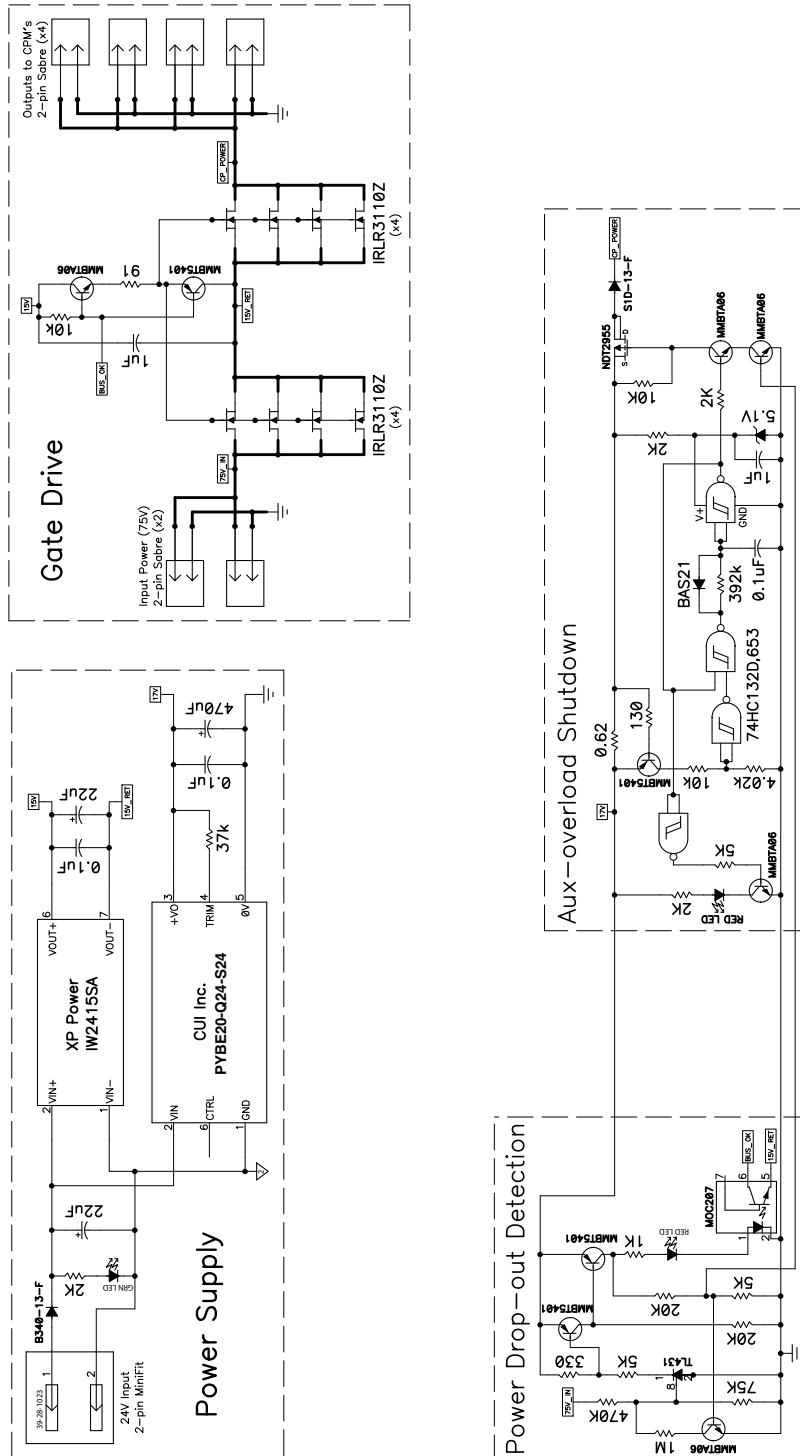

POWER4-HUB simplified schematic

SC4-HUB SCHEMATIC (SIMPLIFIED)

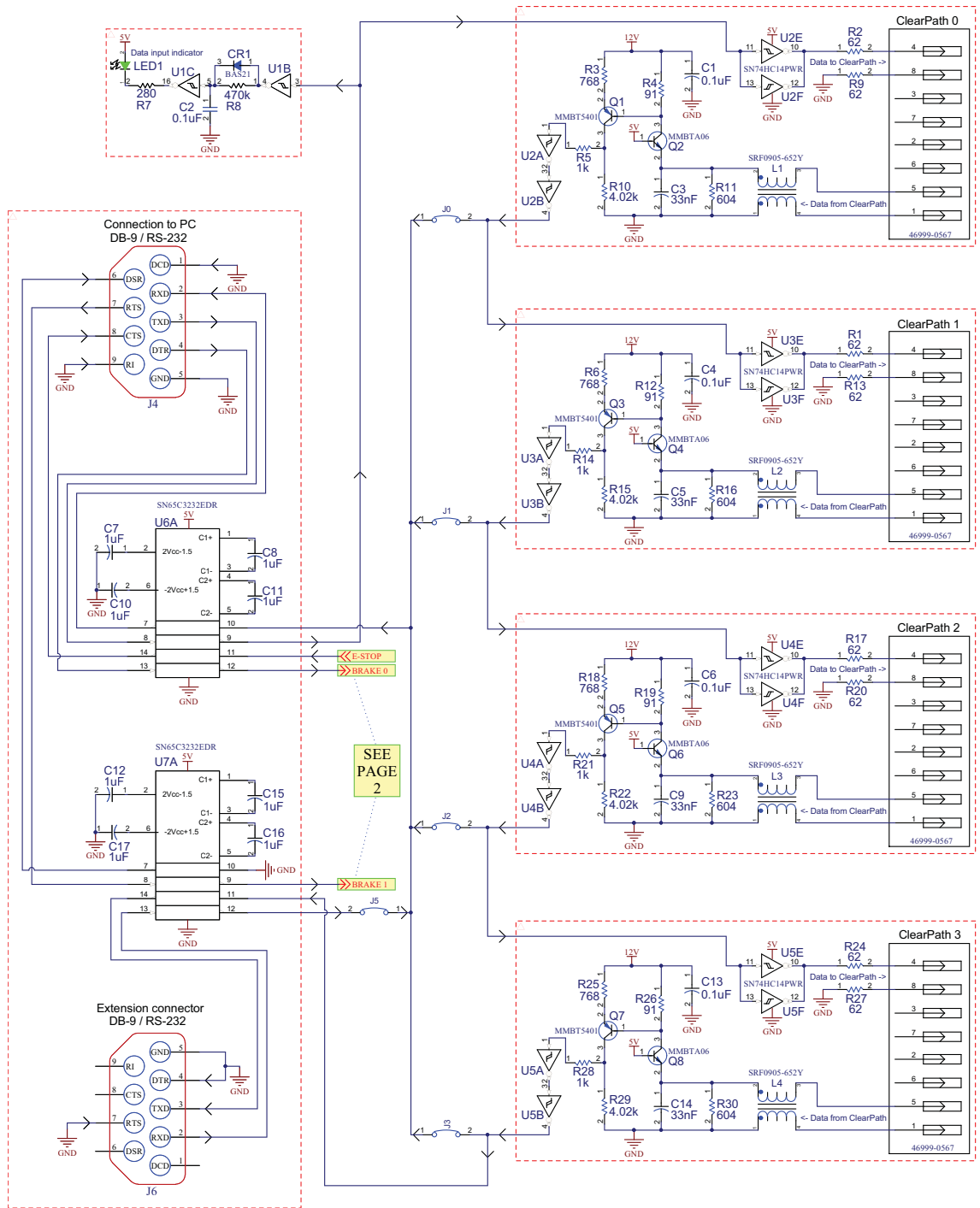

SC4-HUB simplified schematic page 1

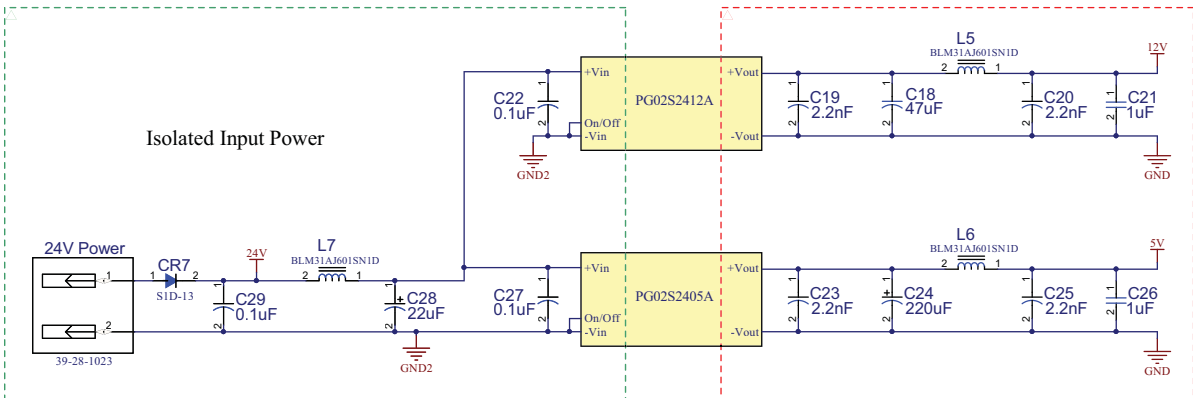
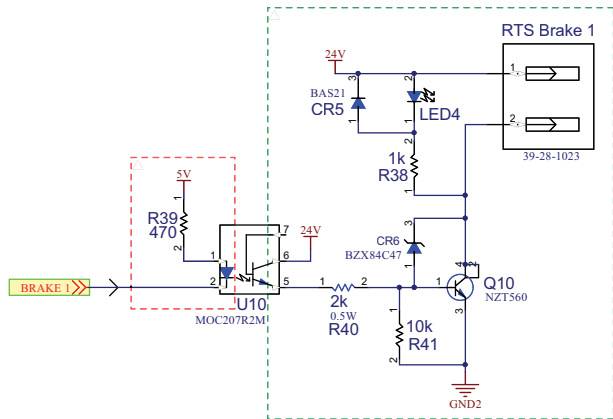
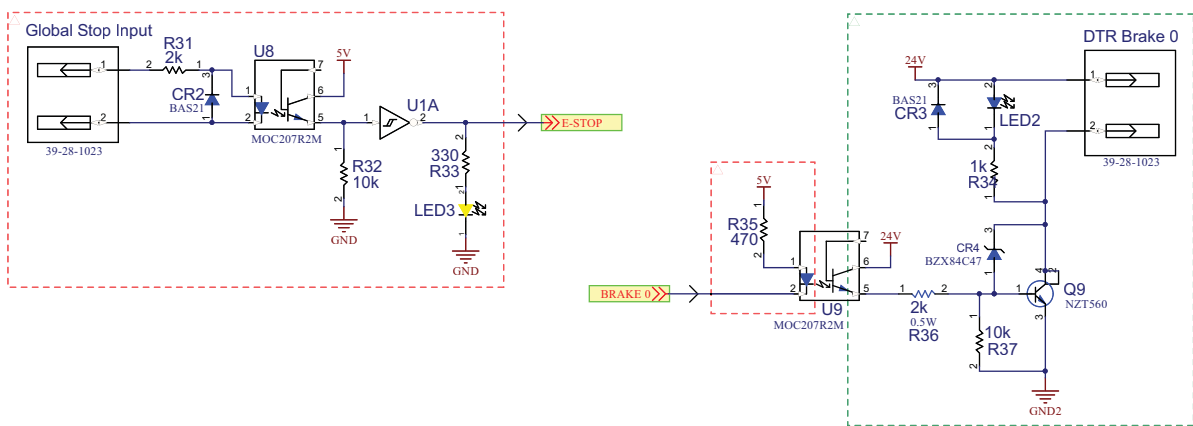

SC4-HUB simplified schematic page 2

APPENDIX G: WIRING THE INPUTS

Each ClearPath-SC motor has two available inputs (Input A and B). Inputs are wired to the SC Hub and passed to the motor via the ClearPath I/O connector as shown below.

WIRING A MECHANICAL SWITCH TO AN INPUT

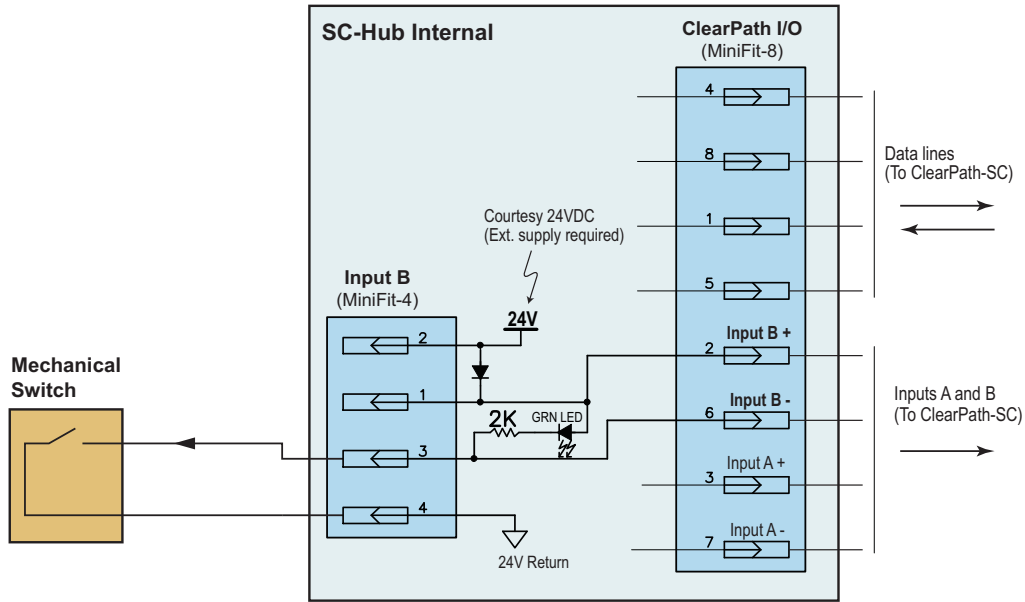

A mechanical switch wired to Input B on the SC Hub

WIRING A 24V NPN SENSOR TO AN INPUT

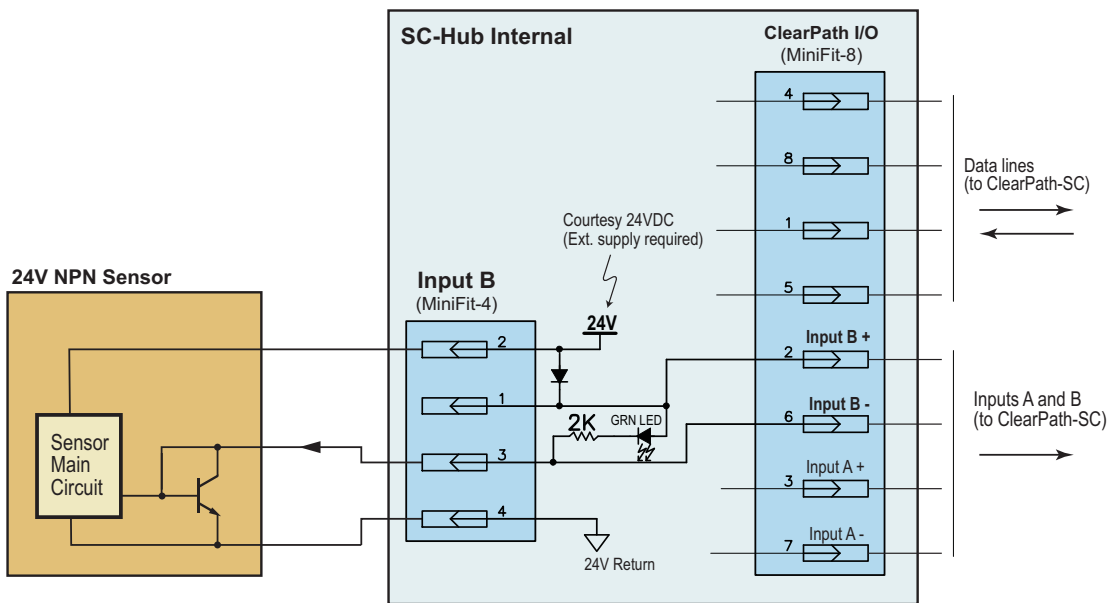

An 24V sensor wired to one input on the SC Hub board

APPLICATION EXAMPLE: WIRING AN OPTICAL SENSOR TO AN INPUT

The example below is based on the Omron EE-SX670 optical slot sensor.

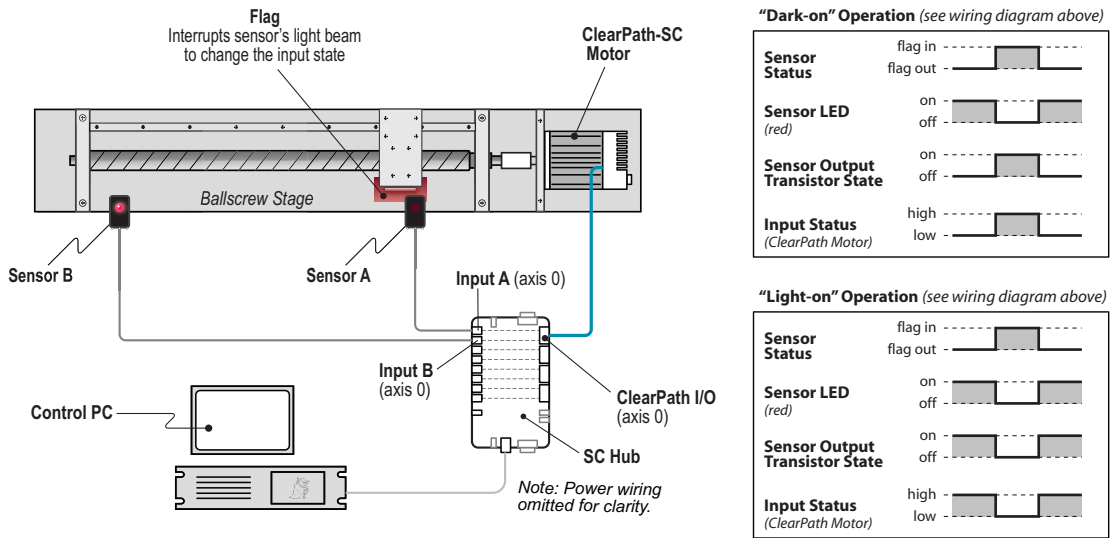
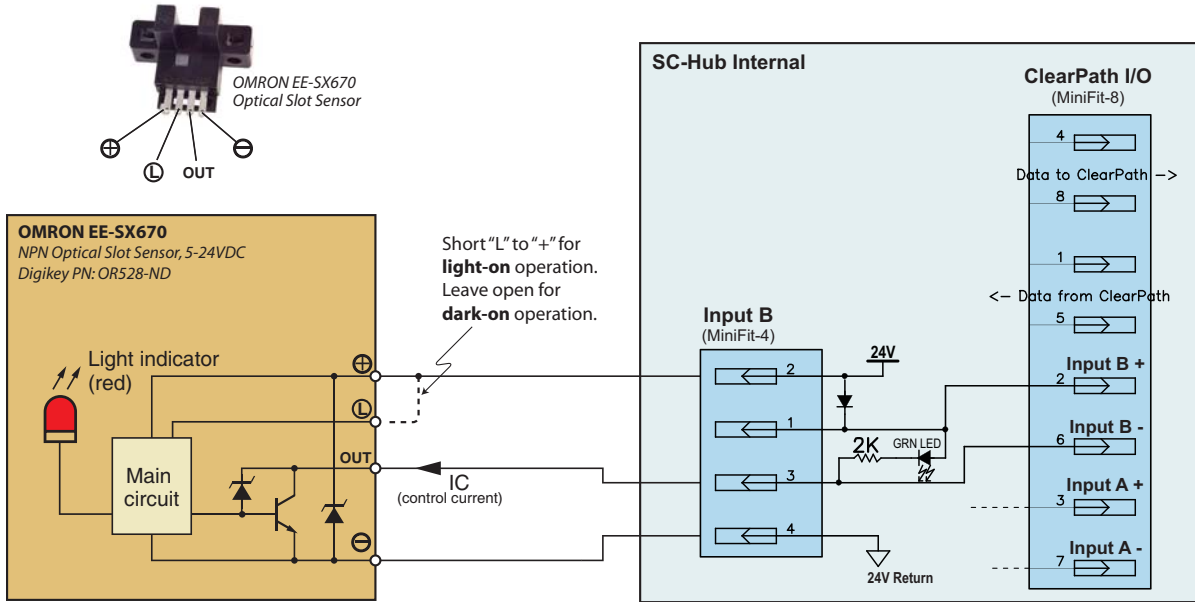

Wiring the Omron EE-SX670 24V optical slot sensor to a CP-SC input

APPENDIX H: MOTOR PART NUMBER KEY

Use the chart below to decode your ClearPath-SC part number, or visit [Teknic's website](#) and enter your motor part number into the search tool for complete information including specifications, torque-speed curves, and links to drawings and documentation.

Example Part Number

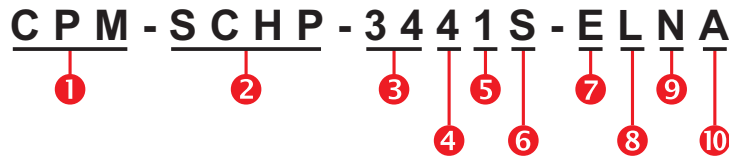

1	Product ID	CPM	ClearPath® Motor
2	Family/Model	SCSK	Software Control / "Stepper Killer" (3x the power of similarly sized steppers)
		SCHP	Software Control / High Power model (8-15 times the power of similarly sized steppers)
3	Motor Frame Size	23	NEMA 23
		34	NEMA 34
4	Approx. Body Length (excluding shaft)	1	82mm
		2	100mm
		3	120mm
		4	140mm
5	Winding/Magnetic Structure	0	Indicates specific winding design. See your motor's torque-speed curve for more information.
		1	
		2	
6	Winding Type	S	Series-Wye (higher torque, lower speed)
		P	Parallel-Wye (in between S and D characteristics)
		D	Parallel-Delta (higher speed, lower torque)
7	Enhanced Options	R	Positioning Resolution = 800 counts per revolution
		E	Positioning Resolution = 6400 counts per revolution
8	Shaft Diameter	L	Standard (1/2" for NEMA 34 models and 3/8" for NEMA 23)
		Q	1/4" shaft diameter (available only on NEMA 23 models with 1 or 2 magnet stacks)
9	Shaft Seal	N	Standard dust sealing
		S	Extra Vytan seal. Seal option "S" not available for 1/4" shaft models.
10	Feature Set	B	Basic features; see list below.
		A	Advanced features; see list below.

Basic Features

- Velocity moves
- Global torque limit
- HardStop foldback (homing)
- Trapezoidal moves
- Node stops / e-stops
- Reading and modifying positions
- RAS™ (jerk limiting)
- Status register
- Warning and alert system
- Parameter memory
- Safety shutdowns
- Soft limits
- User defined data
- Automatic brake coil control
- Group shutdowns

Advanced Features (Includes all Basic Features)

- RAS™ & g-Stop™ (jerk limiting & vibration suppression)
- Positive and Negative torque limiting
- Triggered moves (on input or command, including move groups)
- Head-tail moves
- Asymmetric moves
- A-after-start event generation
- B-before-end event generation
- Conditional torque limiting
- Attention generation

APPENDIX I: LOGIC POWER SUPPLY SIZING

This section was designed to help users estimate how much power (wattage) to specify when selecting a logic power supply for a ClearPath system. The logic supply is typically 24VDC (nominal).

The worksheet below lists the power rating of ClearPath "logic power" system components. Space is provided for calculation of total estimated power usage for any combination of these components.

Additional Notes

- Your ClearPath system may not include all of the components listed below.
- The topic of main DC bus power is not discussed in this section.

Part	Power Req'd (ea)	x	Qty	=	Line Total (Watts)
SC4-HUB	5W	x		=	
Logic power backup: <i>integral hp</i> ClearPath motors (optional)	5W	x		=	
Logic power backup: <i>fractional hp</i> ClearPath motors (optional, and requires POWER4-HUB accessory)	3W	x		=	
POWER4-HUB (for fractional hp motors only, optional)	2W	x		=	
Brake/GPO (optional)	___ W	x		=	
Input Sensors (optional)	___ W	x		=	
Other	___ W	x		=	
Grand Total (Watts)					

APPENDIX J: MISCELLANEOUS

HOW TO MAKE A 24V LOGIC SUPPLY CABLE

All ClearPath-SC systems require a 24VDC supply for the SC Hub and for the Power Hub (if used). The 24 VDC cable must be terminated with a 2-pin Molex connector. This appendix shows a quick, inexpensive way to make a cable for use with a 24VDC supply with no crimping involved.

1. Start by acquiring a 24VDC power supply. A unit with screw terminals is easiest to wire, but almost any type of supply will do. A 1.5 amp supply will generally suffice for smaller systems (4 axes or less), but the *actual minimum current rating depends on the current draw of all devices attached to the supply (sensors, brakes, etc.)*.
2. Order a Teknic **CPM-CABLE-M2P2P-120**. This is a 120" (10-ft.), 2-pin Molex to 2-pin Molex cable as shown below.

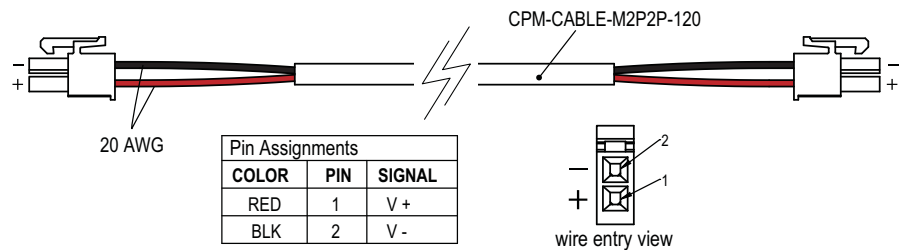

CPM-CABLE-M2P2P-120

3. Cut the cable to the desired length. If you cut it exactly in half, you can make two five foot long cables.
4. Strip the outer jacket and conductors on the unterminated end of the cable to create flying leads.
5. Connect the flying leads to your 24VDC supply. Insulate any exposed conductors with heat shrinkable tubing, electrical tape or similar.
6. **Test DC output polarity before connecting.** Use a DMM to verify proper polarity at the DC output connector. Use the above diagram as a reference.

OTHER PRODUCT NOTES

RE: ELECTRICAL FAST TRANSIENT (EFT) TESTING

Electrical fast transient testing might induce a motor communication error. In such an event, the motor will come to a controlled stop. The communication error can be cleared by a node reset, after which motion can be resumed on command.

CLEARPATH EMC INSTRUCTIONS

<https://tekninc.com/files/downloads/ClearPath EMC Instructions.pdf>

IPC-3/5 THERMAL DERATING DATA

Operating an IPC power supply at ambient temperatures greater than 40C will result in reduced power output. Refer to the data below for derating guidance when operating an IPC-3, IPC-5 power supply or POWER4-HUB at higher ambient temperatures.

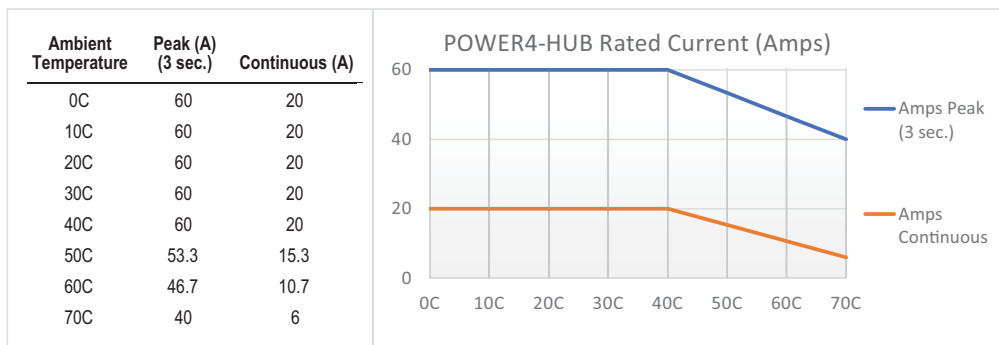
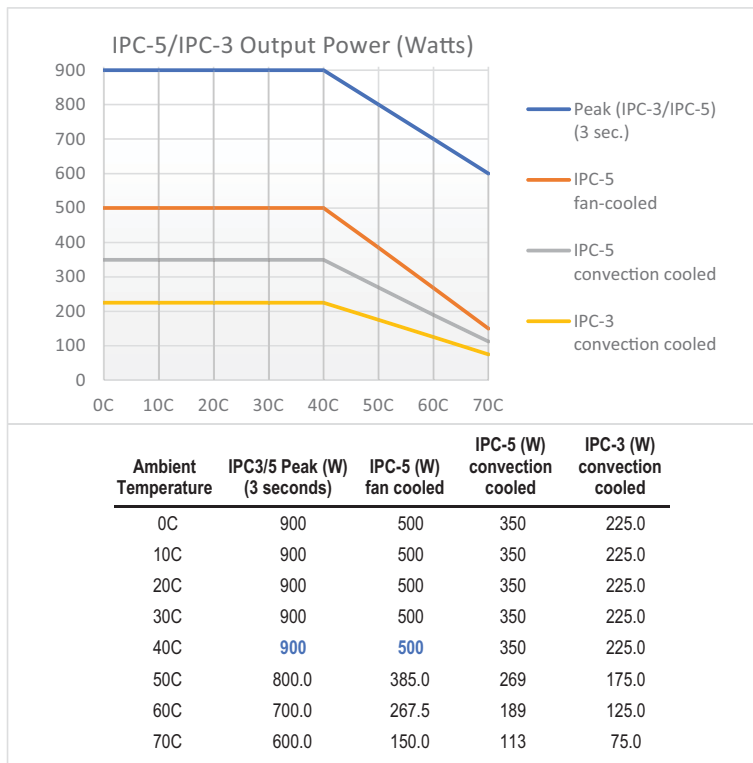

Teknic, Incorporated
7650 Omnitech Pl
Victor, NY 14564

© 2026 TEKNIC INCORPORATED, ALL RIGHTS RESERVED